

Rule Book & Guide to Wrestling

**FREESTYLE, GRECO-ROMAN, WOMEN'S,
and BEACH WRESTLING**

2012 Edition



USA wrestling

FEATURING:

- **Official Rules of FILA**
 - **USA Modifications**
 - **Wrestling Glossary**
 - **A Guide to Pairing**
 - **Tournament Operations**

6155 Lehman Drive

Colorado Springs, CO 80918

www.themat.com

International Rule Book & Guide to Wrestling

**FREESTYLE, GRECO-ROMAN, WOMEN'S WRESTLING,
and BEACH WRESTLING**

2012 Edition



USA wrestling

The 2012 Rule Book & Guide to Wrestling is produced by the Department of State Services of USA Wrestling, in cooperation with the USWOA. For the most up to date version of the Rule Book, please visit www.themat.com/forms/Rulebook.pdf.

USA Wrestling (USAW) is the National Governing Body for the sport in the United States and is the authorized representative to the United States Olympic Committee (USOC), and to the Federation Internationale des Luttes Associees (FILA).

This rule book contains the rules of FILA, which are approved by the USAW Board of Directors to be utilized at USAW sanctioned Freestyle, Greco-Roman, Women's, Beach Wrestling events, as well as USAW sanctioned Grappling Events. Please note the various USAW modifications to the FILA rules which were also adopted by the USAW Board of Directors. The revised 2012 FILA International Rules are made available to download at www.themat.com and are enforced for those events that apply.

USA WRESTLING

James Ravannack President
Rick Tucci President, USWOA
Rich Bender Executive Director

USA Wrestling Rapid Weight Reduction Rule

Whereas rapid weight reduction “cutting weight” through caloric restriction, dehydration, and excessive exercise in heated environments exposes wrestlers to decreased performance, heat related trauma, and hazard to health and life, USA Wrestling (USAW) has adopted the following rules:

With regard to the practice of dehydration, the use of hot rooms, hot showers, hot boxes, saunas, steam rooms, heating devices, diuretics, emetics, laxatives, excessive food and fluid restriction and self-induced vomiting is prohibited by USA Wrestling.

Regardless of purpose, the use of vapor-impermeable suits (e.g., rubber or rubberized nylon) is prohibited.

Violation of these rules at USAW sanctioned events shall cause the individual(s) in question to be suspended from the competition for which use of the prohibited methods were intended.

Enforcement for this rule shall be the responsibility of the tournament committee which is to be established prior to the competition. The decision of the tournament committee shall be final.

A second event violation will result in the suspension of the individual(s) from any USAW sanctioned event for one calendar year from time of suspension. All second violation cases shall be heard by the appropriate age group executive committee. USAW’s bylaws shall be considered in all applicable cases.

Any individual assisting an athlete in prohibited weight reduction practices shall be held to the same rules and penalties as athletes.

USAW discourages rapid weight reduction methods under any circumstances. However, events excluded from these rules are Senior-level FILA calendar events and Senior-level FILA “world level championships” and those Senior-level competitions which are qualifying events for Senior-level FILA “world level championships”.

Guidelines for Application of the Rule:

1. This rule shall be in effect for all USAW sanctioned events (except those excluded above).
2. The tournament committee of each event must put its decision in writing to both the offending party and the USA Wrestling National Office.
3. The rule will be posted/distributed at the competition venue(s), weigh-in site(s), practice venue(s), host hotel(s), training site(s) and official housing facilities(s). In addition, announcements will be made on the public address system throughout the weigh-ins, if possible, and during the competition.

Introduction

There are two basic styles of international wrestling, Freestyle and Greco-Roman. With one major exception, the rules for the two styles are identical. The difference is:

- In Greco-Roman, a wrestler may not attack his opponent's legs, nor use his own legs to trip, lift or execute other holds.
- In Freestyle, however, both the arms and legs may be used to execute holds and to defend against attack.

These definitions bring about variations in stance and technique, and in some interpretations of the rules, but the requirements for scoring points, for winning and losing, and for advancement through an event are in general the same for both styles. A wrestler's goal is to pin his opponent's shoulders to the mat, or else to win on points.

Although freestyle wrestling bears a resemblance to the folkstyle practiced in American scholastic and collegiate programs, there are major differences between the national and international styles. Over the past decade, the International Federation of Associated Wrestling Styles (FILA) has changed the whole direction of the sport.

The objective is to make wrestling vigorous, dynamic and spectacular. This is being carried out by revisions of the rules and their interpretations, by modifications of the methods of pairing, scoring and advancement, and by introduction of new philosophy.

FILA also recognizes two other styles of wrestling each with their own rules, they are Beach Wrestling and Sombo. Details on the rules for these two styles can be obtained through USAW.

Modern Wrestling

Beginning in 2005, FILA adopted sweeping rule changes that changed the image of the sport for the future. On recommendation by various USA Wrestling Age Group Councils and Standing Committees, the USA Wrestling Board of Directors voted that these sweeping rules changes be enforced beginning in 2006, with some modifications. This rule book contains the FILA rules, modification to the rules made by USAW for age group competitions and the rules for Beach Wrestling. All Senior level events and FILA events sanctioned in the United States will adhere to the "new" FILA rules with some modification to the pairings procedures, weigh-ins and protest procedures.

Regardless of what rules are utilized, there are some basic principals that govern the sport overall and the application of any rules currently in place, or that shall be adopted in the future. The principals are as follows:

Passivity (stalling) is the worst enemy of wrestling. Any attempt to avoid wrestling — by blocking, by pushing, by going out of bounds, by "playing the edge."

Total wrestling defines the dynamic, “all-out” aspect of the sport. The wrestlers are expected to attack and counterattack continuously during the wrestling time.

Universal wrestling is an essential quality of total wrestling. It calls for the development of new techniques and the use of a wide variety of actions and holds.

“Risk:” In all sports, attack and defense imply a certain amount of “risk.” A strong wrestler has the courage to take “risks.” Fear and the reluctance to take “risks” should not be a part of wrestling.

Age Group Competition

USA Wrestling sanctions competitive opportunities in Freestyle, Greco-Roman, Beach Wrestling, Sombo and Folkstyle wrestling for all ages and in varying levels of intensity. These programs are not intended to replace scholastic and collegiate folkstyle wrestling, but rather to allow each individual to broaden his/her horizons, increase his/her technical skills and establish new goals.

One of the advantages of wrestling Freestyle, Greco-Roman, Beach and Sombo is that these styles make up an individual sport. Although club and state awards are presented, the wrestler does not have the pressure of performing for his school, the fear of letting down his team. He/she is free to wrestle to win, rather than half-wrestle not to lose.

The club coach most likely is a volunteer. His/Her professional job and his/her family’s livelihood do not depend on the performance of a team. He/she is free to teach new technique, and to encourage his wrestlers to utilize these new skills.

The officials also are volunteers. Generally, there are three on a mat free to make swift, objective decisions about scoring and to enforce the rules and the spirit of the rules. Pairing officials apply standard formulas and procedures, without the need for subjective judgment.

Wrestling in the international styles is the ultimate participation in The Oldest Sport.

USA Wrestling in general follows the Freestyle, Greco-Roman, Grappling, and Beach Wrestling rules of the international governing body, *Fédération Internationale des Luttés Associées*, known as FILA, with modifications for domestic and age group competition. Not all aspects of the international rules are adhered to, and local and state conducted events may include other modifications. As part of its continuing education effort, USA Wrestling presents the 2012 Edition of Guide to Wrestling in the international styles, including the official rules of FILA and guidelines for pairing and tournament operations.

USA Wrestling State Associations & Grass Roots Vision
Statement: *The vision of USA Wrestling is to be the preeminent, most prominent and highly regarded sport organization in the World using Olympic Ideas to assist all in achieving their maximum human potential.*

**INTERNATIONAL FEDERATION OF ASSOCIATED WRESTLING STYLES
INTERNATIONAL WRESTLING RULES**

**GRECO-ROMAN WRESTLING - FREESTYLE WRESTLING
WOMEN'S WRESTLING - BEACH WRESTLING**

INDEX

GENERAL RULES		Page
Article 1	Object	8
Article 2	Interpretation	9
Article 3	Application	9
CHAPTER 1 - MATERIAL STRUCTURE		
Article 4	The mat	10
Article 5	Competitor's dress	11
Article 6	Competitor's licence	13
Article 7	Age and weight categories	13
CHAPTER 2 - COMPETITIONS AND PROGRAMMES		
Article 8	Competition system	16
Article 9	Competition programme	19
Article 10	Award ceremonies	19
CHAPTER 3 - COMPETITION PROCEDURE		
Article 11	Weigh-in	20
Article 12	Drawing of lots	21
Article 13	Starting list	22
Article 14	Pairing	22
Article 15	Elimination from the competition	22
CHAPTER 4 - REFEREEING BODY		
Article 16	Composition	23
Article 17	General duties	24
Article 18	Referee's dress	25
Article 19	The referee	25
Article 20	The judge	26
Article 21	The mat chairman	27
Article 22	The Jury of Appeal	28
Article 23	Penalties against the refereeing body	29
CHAPTER 5 - THE BOUT		
Article 24	Duration of the bout	29
Article 25	Call to the mat	29
Article 26	Presentation of wrestlers	30
Article 27	Start	30
Article 28	Interrupting the bout	30
Article 29	End of the bout	31

Article 30	Interrupting and continuing the bout	31
Article 31	Extra time (freestyle and female wrestling)	32
Article 32	Types of victories	32
Article 33	The coach	33
Article 34	The challenge	34
Article 35	Team ranking during individual competitions	35
Article 36	Ranking system during team competitions	35

CHAPTER 6 - POINTS FOR ACTIONS AND HOLDS

Article 37	Evaluation of the importance of the action or hold	36
Article 38	Danger position	37
Article 39	Recording the points	38
Article 40	High amplitude throw	38
Article 41	Value assigned to the actions and holds	38
Article 42	Decision and vote	40
Article 43	Decision table	41

CHAPTER 7 - CLASSIFICATION POINTS AWARDED AFTER A BOUT

Article 44	Classification points	42
Article 45	The fall	42
Article 46	Technical superiority	43

CHAPTER 8 - NEGATIVE WRESTLING

Article 47	Par terre position during the bout	43
Article 48	Red zone	44
Article 49	Ordered hold	45

CHAPTER 9 - PROHIBITIONS AND ILLEGAL HOLDS

Article 50	General prohibitions	49
Article 51	Fleeing a hold	49
Article 52	Fleeing the mat	50
Article 53	Illegal holds	51
Article 54	Special prohibitions	52
Article 55	Consequences affecting the bout	52

CHAPTER 10 - THE PROTEST

Article 56	The protest	53
------------	-------------	----

CHAPTER 11 - MEDICAL

Article 57	Medical service	55
Article 58	Medical service interventions	56
Article 59	Doping	57

CHAPTER 12 - APPLICATION OF WRESTLING RULES 58

APPENDIX 1 - BASIC VOCABULARY 59

APPENDIX 2 - BEACH WRESTLING 61

USAW Modifications: Modifications to the 2012 international rules, made by USAW to enhance the sport in the United States, are in some cases noted after the text of the international rules in italics or can be found in the section titled "USA Modifications."

See page 136 for USAW Modifications Index

FOREWORD

Wrestling, like all other sports, obeys rules which constitute the “Rules of the Game” and define its practice, the aim of which is to “pin” the opponent or to win on points. These regulations apply to all the styles recognized by modern wrestling controlled by the FILA.

The Greco-Roman Style and Freestyle basically differ as follows:

- In Greco-Roman Wrestling, it is strictly forbidden to grasp the opponent below the belt line, or to trip him or to use the legs actively to perform any action.
- In Freestyle wrestling, however, it is permissible to grasp the legs of the opponent, to trip him and to use the legs actively to perform any action.

Double Nelsons are strictly forbidden in women’s wrestling.

Beach wrestling is dealt with by a specific rule.

Traditional wrestling, as practiced world wide, are subject to specific rules.

Frequently modified and always subject to further modification, the Rules set forth herein must be known and accepted by all wrestlers, coaches, referees and leaders. They call upon those who practice the sport to fight totally and universally, with complete honesty and fair play for the pleasure of the spectators.

FILA

INTERNATIONAL FEDERATION OF ASSOCIATED WRESTLING STYLES

INTERNATIONAL WRESTLING RULES

GRECO-ROMAN WRESTLING - FREESTYLE WRESTLING - WOMEN’S WRESTLING

GENERAL RULES

Article 1 - Object

Drawn up in compliance with the FILA Constitution, the Financial Regulations, the Disciplinary Regulations, the General Rules governing the organization of international competitions, and all the specific Regulations, the International Wrestling Rules have as their specific objectives to:

- define and specify the practical and technical conditions under which bouts are to take place
- determine the value to be assigned to wrestling actions and holds

- list situations and prohibitions
- determine the technical functions of the officials
- determine the competition system, methods of victory, defeat, classification, penalty, elimination of competitors, etc.

Being subject to modification in light of practical observations as to their application and research into their effectiveness, the international Rules set forth in the following document constitute the framework within which the sport of wrestling is conducted in all its styles. Traditional wrestling, Sambo and Beach Wrestling are governed by rules specific to the various styles.

Article 2 - Interpretation

In the event of disagreement as to the interpretation of the provisions of any article in the following Rules, the Executive Bureau of FILA is solely empowered to determine the exact meaning of the article(s) in question. The French text shall prevail.

Article 3 - Application

Application of these Rules to the Olympic Games, Championships, and to all international competitions under the control of FILA is compulsory.

During international tournaments, a competition procedure that differs from that set out in the Rules may exceptionally be used, provided that permission has been granted by FILA and all participating countries.

In the United States, the rules of the sport and modifications to the 2012 FILA rules shall be used at all regional and national events, except whereas noted above. State and local competitions are encouraged to use these rules for consistency from competition to competition.

CHAPTER 1 - MATERIAL STRUCTURE

Article 4 - The mat

USAW Modification In the USA, where mats are manufactured for wrestling competition, the passivity zone may be marked by taping a line of dashes inside the out-of-bounds line. The inner 10-foot folkstyle circle has no meaning internationally, and when standing, the contestants start in the middle, facing each other about a yard apart.

One corner of the mat should be marked in red and another in blue, so the wrestlers and the coaches know where to report. This can be done with colored chairs, with colored plywood under the chairs, or simply with red and blue signs. The red corner should be on the referee's left as he faces the mat chairman's table. FILA approved mats are not required for domestic competition.

For local and state level competitions for the age groups Schoolboy/girl and lower, mats less than full size but not less than a quarter of a full sized (standard) mat may be used when necessary. Adequate protection around all mats should be in place.

A new FILA approved mat, with a 9 m diameter and surrounded by a 1.50 m border of the same thickness is obligatory in the following contests: Olympic Games, Championships and Cups. For all international competitions, mats must be homologated, but not necessarily new.

For the Olympic Games and World Championships, warm up and training mats must also be new and approved by FILA and be of the same quality as the competition mats.

A red band of 1 m wide and forming an integral part of the wrestling area is drawn along the circumference on the inside of the circle of 9 m in diameter.

The following terms will be used to designate the various parts of the mat:

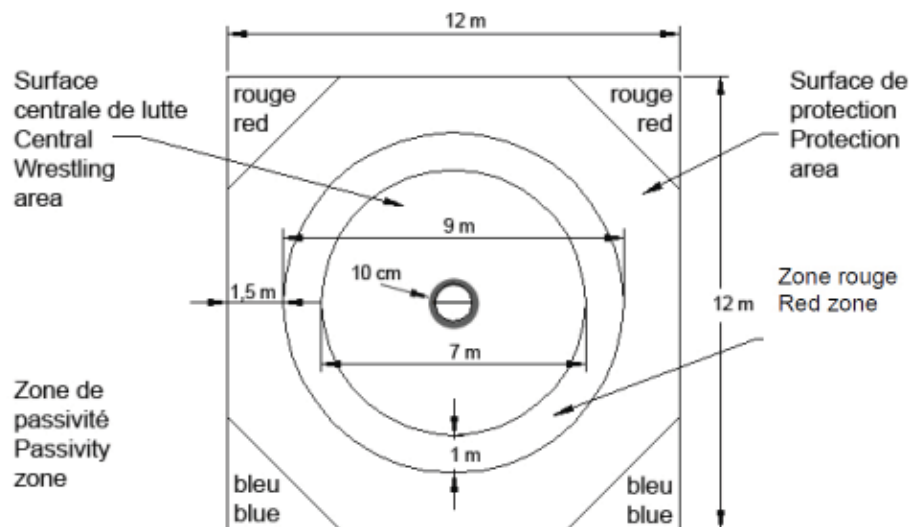

The central circle indicates the middle of the mat (1 m diameter). The inside part of the mat which is inside the red circle is the central surface of wrestling (7 m of diameter). The red strip (1 m width). The area in the protection area is 1.50 m width

For all Olympic Games, World Championships and Continental Championships, the mat shall be installed on a platform not higher than 1m10 or lower than 0m50.

If the mat lays on a podium and that the protection margin (covering and free space around the mat) does not reach 2 meters, the sides of the podium will have to be covered with 45° inclined panels. In all cases, the color of the protection area will have to be different from the one of the mat.

The wooden floor near the mat will have to be covered with a strongly well fixed soft cover.

To prevent contamination, the mat must be washed and disinfected before every wrestling session. When mats that have a smooth, uniform and non-abrasive surface are used (canvas included), the same hygienic measures must also be applied.

A circle must be traced in the middle of the mat with an inside diameter of one meter and a surrounding band 10 cm wide. For Greco-Roman wrestling, an 8 cm width line splits the circle in two parts. The color of the line just described and that of the line marking off the wrestling area must be red.

The diagonally opposite corners of the mat are marked out in the wrestlers' colors, red and blue.

The mat should be installed so that it is surrounded by a wide open space in order to ensure that the competition proceeds normally.

Article 5 - Competitor's dress

USAW Modification: (a) Singlet: The singlets for Cadet, FILA Cadet and Junior Division National Championships are to be colored predominantly a clearly distinguishable shade of either red or blue. Red and blue may be mixed as long as the provisions above remain. No specific rules for any other competitions, (b) For Cadet and Junior Division National Championships, athletes must wear their state approved singlet, (c) The use of protective headgear of a type required for scholastic wrestling is authorized and recommended in Junior, Cadet, FILA Cadet competition. Headgear is allowed in Senior, University and FILA Junior World competition, but must be removed at the request of the opponent unless it is worn for a certified medical reason. Headgear is mandatory for all 14 and younger USAW Regional and National Championships. In any division, a face mask is allowed only to protect an existing injury, or an injury occurring during the bout, and must be prescribed by a medical doctor or the event's chief medical officer. (d) Competitors are required to tape their shoe laces down to avoid unfastening.

At the beginning of each day, each competitor must be closely shaven or have a beard of several months growth.

a) The competition singlet

Contestants must appear on the edge of the mat wearing a FILA approved one-piece singlet of the colour assigned to them (red or blue). It is forbidden to have a mixture of red and blue colours on the singlet. *Only for the USAW Senior Team Trials shall athletes be required to wear the "high cut" singlet as stipulated by FILA. The use of a two-piece singlet/uniform is **not** allowed at any freestyle or Greco-Roman USAW Developmental Age Group Regional or National Championships. Folkstyle wrestlers **are** allowed to wear compression or board shorts and a tight-fitting sleeveless, short, or long sleeve shirt (shorts shall be excessively baggy or have pockets, buttons, or snaps).*

The wrestler must wear:

- Their country's emblem on his chest.
- The abbreviation of the country's name (maximum size 10 cm x 10 cm) on the back of the singlet and the last name in latin letters (4 cm to 7 cm) above or in a half circle around the country's abbreviation
- The use of light knee pads containing no metal parts is allowed.
- The wrestler must have a cloth handkerchief with him during the whole of the match.

b) Advertising on clothing

Apart from during the Olympic Games where the IOC Rules apply, competitors can wear one or several sponsor's names. Contestants may also wear their sponsors' name(s) on the back or sleeves of their robes. Lettering and symbols may not be higher than 6 cm to identify the sponsor.

c) Ear protectors

For those wrestlers who wish to wear ear protectors, they must be approved by FILA and must not contain any metal or have hard shells.

The referee can oblige a wrestler with too long hair to wear ear protectors. *(Standard headgear manufactured in the United States may be worn for all domestic USAW events. Headgear is mandatory of 14 years and younger athletes at all USAW Regional and National competitions.)*

d) Shoes

Contestants must wear wrestling shoes providing firm support for the ankles. The use of shoes with heels or nailed soles, shoes with buckles or with any metallic part, is prohibited. Shoes may be without laces. Shoes with laces should be wrapped with sticky tape or a system which hides laces so that they do not come undone during the match. Each competitor is responsible for providing the tape himself for the shoes which will be controlled before getting on to the mat.

e) Bans

At the weigh-in, the referee must check that each competitor satisfies the requirements of this article. The wrestler must be warned at the weigh-in that, if his appearance is not correct, he will not be allowed to enter the competition. If the wrestler enters the mat with a non compliance appearance, officials will allow maximum one minute in order for him to comply. If, after this time, the wrestler is still at fault, he will lose the match by abandon.

It is prohibited to:

- Wear the emblem or abbreviation of another country.
- Wear bandages on wrists, arms or ankles except in the case of injury and on doctor's orders. These bandages must be covered with elastic straps.
- Apply any greasy or sticky substance to the body.
- Arrive at the mat perspiring for the beginning of the match as well as at the beginning of each period.
- Wear any object that might cause injury to the opponent, such as rings, bracelets, prosthesis, etc.
- Wear underwired bras for female wrestlers.

Article 6 - Competitor's licence

Any male or female senior wrestler who competes in the Olympic Games, World Championships, World Cups, Continental Championships, Cups and Games, Regional Games and the World and Continental League, international tournaments registered in the FILA calendar must hold an international competitor's licence, as defined by special Regulations. *For USAW events, all competitors must be current members of USAW.*

Any male or female cadet, junior wrestler who competes in the Continental and World Championships must hold an international competitor's licence.

Any male or female junior wrestler who competes in a senior international tournament must hold an international competitor's licence.

Any veteran wrestler who competes in the World Championships and other international competitions must also hold an international competitor's licence.

This licence is also used as insurance for medical and hospital expenses in case of an accident taking place during competitions he is participating in.

The competitor must, at the time of the weigh-in, present his licence to the official delegate who, in turn shall submit it for verification to the FILA representative. The latter shall return it on the same day to the team manager of the said competitor. For competitions in which no accreditation is organized, these documents must be presented at weigh-in.

The licence is valid only when it bears the FILA stamp for the current year, and must be renewed each year.

Article 7 - Age and weight categories

a) Age categories

The age categories are as follows:

Schoolboys	14-15 years (from 13 with medical and parental certificate)
Cadets	16-17 years (from 15 with medical and parental certificate)
Juniors	18-20 years (from 17 with medical and parental certificate)
Seniors	20 years and older
Veterans	older than 35 years

Wrestlers in the junior age category are allowed to participate in the competitions for seniors. However, wrestlers aged 18 in the year concerned must provide a medical certificate and parental authorization. Wrestlers aged 17 in the year in question may not participate in senior competitions.

Age will be verified at all Championships and competitions during the accreditation.

An honour certificate for each participant will be issued by the President of the National Federation attesting to the age of the wrestler; this certificate must be drawn up in accordance with the model supplied by FILA, on the National Federation's letterhead.

A wrestler may participate in a competition only under the nationality appearing on his passport. If, at any time, it is determined by FILA that the statement was false and that fraud occurred, the disciplinary measures provided for to this end will be immediately applied against the Federation, the wrestler and the person whose signature appears on the fraudulent certificate.

Wrestlers who change their nationality and wish to participate in an international competition with their new country must wait two (2) years after their last competition registered in the FILA calendar. Wrestlers can change their nationality only once. Afterwards, they cannot compete for their old country anymore.

Each wrestler who participates in a competition automatically agrees to FILA **and USAW** to use his filmed or photographed image for the promotion of the competition or of competitions to come. If a wrestler refuses to agree to these conditions, he will have to make this clear at the entry stage and, may therefore be excluded from the competition.

b) Weight categories

The weight categories for freestyle and Greco-Roman are as follows:
(USAW weight classes differ)

SCHOOLBOYS	CADETS	JUNIORS	SENIORS
1. 29-32 kg	1. 39-42 kg	1. 46-50 kg	1. 50-55 kg
2. 35 kg	2. 46 kg	2. 55 kg	2. 60 kg
3. 38 kg	3. 50 kg	3. 60 kg	3. 66 kg
4. 42 kg	4. 54 kg	4. 66 kg	4. 74 kg
5. 47 kg	5. 58 kg	5. 74 kg	5. 84 kg
6. 53 kg	6. 63 kg	6. 84 kg	6. 96 kg
7. 59 kg	7. 69 kg	7. 96 kg	7. 96-120 kg
8. 66 kg	8. 76 kg	8. 96-120 kg	
9. 73 kg	9. 85 kg		
10. 73-85 kg	10. 85-100 kg		

The weight categories for female wrestling are as follows

SCHOOLBOYS	CADETS	JUNIORS	SENIORS
1. 29-32 kg	1. 39-42 kg	1. 46-50 kg	1. 50-55 kg
2. 35 kg	2. 46 kg	2. 55 kg	2. 60 kg
3. 38 kg	3. 50 kg	3. 60 kg	3. 66 kg
4. 42 kg	4. 54 kg	4. 66 kg	4. 74 kg
5. 47 kg	5. 58 kg	5. 74 kg	5. 84 kg
6. 53 kg	6. 63 kg	6. 84 kg	6. 96 kg
7. 59 kg	7. 69 kg	7. 96 kg	7. 96-120 kg
8. 66 kg	8. 76 kg	8. 96-120 kg	
9. 73 kg	9. 85 kg		
10. 73-85 kg	10. 85-100 kg		

Each contestant deemed to be taking part of his own free will, and responsible for himself, shall be allowed to compete in only one weight category: the one corresponding to his weight at the time of the official weigh-in.

For categories in the senior age group (*all age groups for USAW competitions*), competitors may opt for the next higher category than their body weight, except for the heavy weight category, for which contestants must weigh over 96 kg (females over 67 kg), *or the highest weight class prior to last weight class of the appropriate age group for USAW competitions. Rules differ for National Dual Championships.*

c) Competitions

International competitions for the various age categories are as follows: (*USAW age groups and competitions differ*)

Schoolboys (14-15 years)	International competitions (bilateral and regional)	
Cadets (16-17 years)	International competitions	
	Continental Championships	(each year)
Juniors (18-20 years)	International competitions	
	Continental Championships	(each year)
	World Championships	(each year)
Seniors (20 years and older)	International competitions	
	Continental Championships	(each year)
	Continental Cups	(each year)
	World Championships	(each year,
	apart from Olympic Games years)	
	World Cup	(each year)
	Golden Grand Prix	
Challenge matches		
Veterans (35 years and older)	International Grand Prix	
	Super Star matches	
	Olympic Games	(every four years)
	Competitions according to the programme	(each year)

Categories and specific regulations

All previously mentioned competitions will be conducted according to FILA Rules, Statutes and Regulations, or as modified by USAW for domestic competitions, which shall use the 2012 FILA Rules as modified by USA Wrestling, and with exceptions herein noted.

CHAPTER 2 - COMPETITIONS AND PROGRAMMES

Article 8 - Competition system

Competition System and Method

USA Wrestling competition procedures may be found on page 61.

The competitions take place by direct elimination system with an ideal number of wrestlers, i.e. 4, 8, 16, 32, 64, etc. If there is no ideal number of wrestlers in a category, qualification matches will take place.

Pairing is made in the order of the numbers drawn at random. All wrestlers who lost against both finalists will have repêchage matches. There are two separated groups of repêchage : one group of wrestlers who lost against the first finalist, and another group of wrestlers who lost against the second finalist. The repêchage matches begin with wrestlers who lost in the first round including in matches to obtain the ideal number against one of the two finalists up to the losers in the semi-finals by direct elimination. The winners of the two repêchage groups will receive each the bronze medal.

Each weight category begins and ends in a day. Each category weigh-in takes place the day before the beginning of the category concerned.

The competition takes place in the following manner:

- a) qualification round
- b) elimination round
- c) repêchage round
- d) finals

If there are less than 6 wrestlers in a weigh-in category, the Nordic round will take place (each wrestler against each wrestler).

Example of a competition by direct elimination

Let us take the example of a competition with 22 wrestlers in a weight category. The 22 wrestlers draw a number at random from 1 to 22.

Qualification rounds

In order to obtain the closest lower ideal number to apply the direct elimination system (16 wrestlers), qualification matches must take place.

In our example, we have 6 wrestlers with the ideal number of 16. The qualification matches will be disputed by 6 wrestlers who drew the highest numbers after 16, i.e. 17, 18, 19, 20, 21 and 22 and by 6 wrestlers drawing the

numbers at random directly before 17, i.e. 16, 15, 14, 13, 12, 11. According to the pairing principle in the order of the numbers drawn at random, the matches take place in the following manner :

- Number 11 against number 12, match number 1
- Number 13 against number 14, match number 2
- Number 15 against number 16, match number 3
- Number 17 against number 18, match number 4
- Number 19 against number 20, match number 5
- Number 21 against number 22, match number 6

The winners of these 6 qualification matches are qualified for the elimination round by direct elimination.

Elimination round

We have the ideal number of 16 wrestlers after the qualification matches. The 16 wrestlers competing for the elimination round are the 10 wrestlers who drew the numbers from 1 to 10 and the 6 wrestlers who won the qualification matches, i.e. numbers 12, 13, 15, 17, 19 and 22 (to arrive at 16). According to the pairing principle in the order of the numbers drawn at random, the first elimination round takes place in the following manner:

- Number 1 against number 2, match number 1
- Number 3 against number 4, match number 2
- Number 5 against number 6, match number 3
- Number 7 against number 8, match number 4
- Number 9 against number 10, match number 5
- Number 12 against number 13, match number 6
- Number 15 against number 17, match number 7
- Number 19 against number 22, match number 8

Repêchage matches

As mentioned above, all the wrestlers losing against the two finalists will make up a repêchage.

The wrestlers losing against the finalist no 5 are as follows:

- Number 6 (1st round loser)
- Number 7 (2nd round loser)
- Number 3 (3rd round loser)

The wrestlers losing against the finalist no 15 are:

- Number 16 (qualification round loser)
- Number 17 (1st round loser)
- Number 19 (2nd round loser)
- Number 12 (3rd round loser)

The repêchage phase begins with the wrestlers who lost against the finalists at the lowest level of competition.

1st match: no 6 (1st round loser) against no 7 (2nd round loser)
2nd match: 1st match winner (N6) against no 3 (3rd round loser)

The wrestler 6 is the winner in the repêchage group who lost against the no 5 finalist.

The same system applies to the wrestlers losing against the no 15 finalist.

1st match: no 16 (qualification round loser) against no 17 (1st round loser)
2nd match: the winner of the 1st match (N16) against no 19 (2nd round loser)
3rd match: 2nd match winner (N16) against no 12 (3rd round loser)

The no 16 wrestler is the winner of the repêchage group who lost against the no 15 finalist.

Final

The two finalists in the elimination rounds, i.e. no 5 and 15, take part in the match for the 1st and 2nd places.

The two winners of the two last repêchage matches (N6 and N16) receive each the bronze medal.

The losers of both finals for the two bronze medals will be ranked 5th ex aequo.

Classification criteria

From the 7th place, wrestlers of each category will be ranked depending on their ranking points, retirement or forfeit, injury or disqualification.

In case of a ranking tie, they will be ranked by analyzing the following criteria successively:

- 1) The most victories by "Fall"
- 2) The most matches won by superiority
- 3) The most periods won by superiority
- 4) The most technical points scored in all the competition
- 5) The fewest technical points given in all the competition

If the place of the wrestlers cannot be determined with the above mentioned criterion, they will be ranked ex aequo.

The wrestlers taking part in the repêchage phase will also be ranked according to the ranking points earned during the competition, including qualification matches and repêchage.

N.B. Disqualified wrestlers for brutality or unfair behavior will be eliminated and not classified. Except with a medical certificate controlled by a FILA Doctor, if a wrestler does not present himself to the mat for whatever reason as soon

as the competition has started, his opponent(s) will win the match, and the wrestler will be eliminated and not classified.

Ranking criteria for the Nordic tournament

- a. Only 4 classification points will be attributed for the fall for the Nordic tournament system.
- b. In the Nordic tournament the wrestler with the most ranking points is classified first.
- c. If two wrestlers have an equal number of classification points, their direct fight will determine the winner. The wrestler who wins against his opponent will be ranked 1st.
- d. If several wrestlers have an equal number of classification points, the last of the ex-equo group will be classified following these criterion until only two wrestlers remain :
 - 1) The fewest victories by "Fall"
 - 2) The fewest match victories by superiority
 - 3) The fewest period victories by superiority
 - 4) The fewest technical points scored in the whole competition
 - 5) The most technical points given in the whole competition

If two wrestlers have an equal number of classification points, the winner of their bout will be ranked 1st.

Article 9 - Competition programme

In the United States, the "Competition Program" shall be established by USA Wrestling and published in event flyers and/or on USA Wrestling's website at www.usawrestlingevents.com for each specific event.

The duration of Olympic Games is 8 days on 3 mats.

The duration of the senior and junior World Championships is 6 days for three styles (FS, GR, FW) on 3 mats. However depending on the number of entries received, one mat can be added or withdrawn for all competition types with FILA's agreement.

In principle, for all competition types, the matches shall not last longer than three hours. For all competition types, a weight category begins and ends after maximum one day.

For each competition round a weight category must in principle take place on the same mat and not on several mats at the same time. All the matches for the 1st, 2nd and 3rd places must take place on one mat.

Article 10 - Awards ceremony

The number of awards and manner in which they are presented shall be determined by USAW and may differ from event to event.

The first four wrestlers in each weight category shall take part in the awards ceremony, and shall receive a medal and a diploma, according to their ranking.

1st	GOLD
2nd	SILVER
The two 3rd	BRONZE
5th-10th	DIPLOMA

At the World Championships, the winner will receive the World Championship Belt. (See Rules governing distinctions and awards).

Awards ceremonies take place immediately after the final match of the category concerned.

CHAPTER 3 - COMPETITION PROCEDURE

Article 11 - Weigh-in (not all rules are applicable to USAW sanctioned events)

The final list of contestants must be submitted to the organizer by the team manager, without fail, 6 hours before the start of the weigh-in. No changes will be accepted after this time.

The weigh-in for each category always takes place on the day before the beginning of the competition concerned and lasts 30 minutes.

No wrestler may be accepted at the weigh-in if he has not undergone medical examination within the period set up in the competition regulations. Medical examinations are always carried out one (1) hour before the weigh-in.

Wrestlers must turn up at the Medical examination and the weigh-in with their license and passport, or with their accreditation card alone if the identity control took place at accreditation.

The contestants will be weighed with only their singlet, after having been examined by qualified physicians who are obliged to eliminate any wrestler who presents any danger of contagious disease. ***For USAW competitions, the singlet worn to weigh-in must be an approved competition singlet without modification.***

No weight tolerance will be allowed for the singlet.

Contestants must be in perfect physical condition, with their fingernails cut very short.

Throughout the entire weigh-in period, wrestlers have the right, each in turn, to get on the scale as many times as they wish.

Referees responsible for the weigh-in must check that all the wrestlers fulfil all the requirements of Article 5 - Competitor's Dress - and to inform any wrestler of the risk he runs if he presents himself on the mat in incorrect dress. Referees will refuse to weigh a wrestler who is not dressed correctly.

USAW Modification: *For Cadet & Junior Division National Championships multiple day weigh-ins have been adopted and weigh-ins shall occur a maximum of 4 hours prior to initial competition. For the second day weigh-in a 2 lb allowance shall be given. For the Kids FS/GR Nationals, and Kids/Cadet Regional Competitions weigh-ins shall occur as established by the Kids/Cadet Council and Region Councils respectively. For Kids/Cadet Region competition, an athlete may weigh in for both styles at the first style's initial weigh-in if competing in the first style. For all Junior Division Regionals, weigh-ins shall occur a maximum of 3 and minimum of 2 hours prior to competition on first day of competition, and athletes may weigh in for both styles at the first style's initial weigh-in if competing in the first style. For all other divisions weigh-ins shall occur as established by their respective National Councils or Sports Committee. For all Kids, Cadet, FILA Cadet, Junior, FILA Junior, University division regional and national events, weigh-ins shall begin at the designated time to conclusion, except when the competition is a qualifying event for a World level competition. In that case the FILA rules shall apply, with USA Wrestling modifications. All athletes must be present at the beginning of the designated weigh-in time. Athletes shall have two consecutive attempts to make weight, the initial attempt when called to the scale and an immediate challenge of another scale located in close proximity to the initial weigh-in scale(s). Athletes may not leave the weigh-in area or initiate any activity for means of weight reduction. Complete information may be requested from USAW. For all National Competition, all divisions except the Kids Division must weigh-in for each style if participating in each.*

USAW Modification: FAILURE TO WEIGH IN - *For Kids, Cadet, FILA Cadet and Junior divisions, a wrestler who does not weigh in, or fails to make weight at a second weigh-in, cannot place and is eliminated. No other athletes may be moved up, outside the final four in each pool, for placing purposes. This rule does not apply to wrestlers issued a red Medical Alert form.*

Article 12 - Drawing of lots (optional for USAW events, random computerized drawing of lots may be utilized)

Participants shall be paired off for each round according to the numerical order determined by the drawing of lots during the weigh-in. The drawing of lots must be conducted in public. The Heracles software shall be used for the weigh-in and management of all international competitions entered in the FILA calendar.

If the Heracles software cannot be used, numbered tokens corresponding to the number of wrestlers who underwent a medical examination must be enclosed in an urn, a bag or any other similar object. If a different system is used, it must be clear.

The wrestler shall be weighed, and, as he leaves the scales, shall draw his number, on the basis of which he shall be paired off.

This number must be immediately entered on a notice board visible to the public, as well as on the starting and weigh-in list.

Important: When the person responsible for the weigh-in and drawing of lots observes an error in the regulation procedure as outlined above, the drawing of lots for the category in question is to be cancelled. Drawing of lots for this category will then be repeated with the agreement of the technical delegate.

USAW Modification: *For all USAW Divisions Region and National Competitions, drawing of numbers (lots) shall occur at event registration on site or during the weigh-in. In addition, when computer assisted pairing is conducted, drawing of lots by a computer is authorized and approved.*

Article 13 - Starting list

If one or more wrestlers do not attend the weigh-in or are too heavy, after the weigh-in, wrestlers are regrouped in a precise order of classification from the lowest to the highest number.

No. 1	E	No. 7	J	
No. 2	H	No. 8	L	
No. 3	B	No. 9	I	(Wrestlers are therefore
No. 4	A	No. 10	G	regrouped by numerical order.)
No. 5	D	No. 11	K	
No. 6	C	No. 12	R	

Article 14 - Pairing

For all USA Wrestling sanctioned regional and National events, wrestlers shall be paired off according to the procedures and policies established for the specific event, see page 85. A document establishing the correct procedure and time schedule of the bouts must be drawn up, and it must provide all the relevant information concerning the manner in which the competition is to be conducted.

Wrestlers shall be paired off in the order of the numbers they drew. A document establishing the correct procedure and time schedule of the bouts must be drawn up, and it must provide all the relevant information concerning the manner in which the competition is to be conducted.

The pairing for each round, as well as the results, are recorded on a board for use by the competitors, who must be able to consult it at all times. (See above table.)

Article 15 - Elimination from the competition

- The loser is eliminated and ranked according to the classification points marked, except wrestlers who lost against one of the finalists as they take part in the repêchage for the 3rd or 5th places.

- A wrestler who, without medical advice and without notifying the official Secretariat, does not present himself to his opponent when his name is called is disqualified and not placed. His opponent(s) will win the match. **USAW Modification:** see page 66.
- If a wrestler commits an obvious offense against fair play within the spirit and concept of total and universal wrestling enunciated by FILA, and openly cheats, commits a serious error or engages in brutality, he will be disqualified immediately from the competition and eliminated by a unanimous decision of the officiating team. In this situation, he will not be placed.
- If two wrestlers are disqualified for brutality during the same match, they will be eliminated as above. The pairing for the following round will not be modified. The wrestler supposed to meet one of the disqualified wrestlers wins the match.
- If this qualification perturbs the ranking in a final match, the following wrestlers will move up the table to establish the final classification. If the two finalists are disqualified, then it will be necessary to make the bout between the two bronze medalists to determine the 1st and the 2nd place. All others participants will go up in the ranking, the two in 5th position will become 3rd.

Ranking in the event of doping violations

If the 1st or 2nd ranked wrestler is disqualified for doping, the bronze medallist who lost by elimination from the repêchage group of that particular finalist shall move up to second place.

The loser of the repêchage group from the finalist disqualified shall move up and will receive the bronze medal. For the rest of the ranking, the other wrestlers will move up in placing according to the ranking system.

In case of positive doping control, the wrestler will be disqualified, and not placed.

CHAPTER 4 - REFEREEING BODY

Article 16 - Composition

USAW Modification: *Due to the nature of many USAW sanctioned local and state events, and in some cases regional championships, the use of three officials is not required.*

In all competitions, the officials for each bout shall consist of the following:

- 1 mat chairman
- 1 referee
- 1 judge

The appointment procedures of these three officials are set in the Regulations for the International Refereeing Body. Replacement of an official during a bout is strictly prohibited, except in the case of a serious illness that is medically confirmed.

In no case may two officials be of the same nationality.

Furthermore, it is strictly forbidden for an official to officiate in bouts involving compatriot wrestlers.

The refereeing body shall make all decisions unanimously or by majority of two on one, except in fall situations where the mat chairman's approval must be obtained. It cannot use video evidence to make its decisions (except in case of challenge)

Jury of Appeal

The Jury of Appeal is a group of refereeing experts whose function is to make sure that the wrestling rules are strictly applied during all major FILA events, such as: the Olympic Games, the World and Continental Championships, the World Cups, the Golden Grand Prix tournaments, and the specific Games.

Article 17 - General duties

a) Officials shall perform all the duties set forth in the Regulations governing wrestling competitions and in any special provisions which might be established for the organisation of particular competitions.

b) It is the duty of officials to follow each bout very carefully and to evaluate the actions of the wrestlers so that the results shown on the judge's score sheet accurately reflect the specific nature of said bout.

c) The mat chairman, referee and judge shall evaluate the holds individually in order to arrive at a final decision. The referee and judge must work together under the direction of the mat chairman, who co-ordinates the work of the officials.

d) It is the duty of the officials to assume all of the functions of refereeing and judging, to award points and to impose the penalties stipulated in the Rules.

e) The score sheets of the judge and mat chairman are used to tally all the holds executed by the two opponents. The points, cautions (0) must be recorded with the greatest accuracy, in the order corresponding to the various phases of the bout. These score sheets must be signed by the judge and mat chairman, respectively.

f) If a period does not end in a "fall," the decision shall be made by the mat chairman. It shall be based on an evaluation of all the actions of each competitor, recorded from beginning to end on the judge's and mat chairman's score sheets.

g) All the points awarded by the judge must be announced to the public as soon as they are determined, either by means of bats or by an electric scoreboard.

h) Officials are required to use the basic FILA vocabulary that is appropriate to their respective roles when conducting the bouts. However, they are forbidden to speak to anybody during the bout, except, of course, amongst themselves when the occasion requires them to do so for consultation and to perform their tasks properly.

i) When a challenge is requested by a coach and confirmed by the wrestler, the refereeing body must watch the video evidence on big screen at same time as the jury of appeal, without leaving their seats. After having reviewed the action once, the refereeing body announces its decision that will be confirmed or corrected by the Jury of Appeal.

Article 18 - Referee's Dress

USAW Modification: *This regulations may be modified by local and state rules and may be modified by the appropriate USWOA representative assigned to regional and national competitions. For all USAW National Competition the official's uniform shall be: Light Blue Polo Shirt, Grey Trousers, Black Belt, Black Shoes (athletic type). Contact USAW for details on ordering.*

The refereeing body(referees, judges, mat chairmen, and jury members) must be dressed in the following manner when exercising their function:

- classic navy jacket with FILA logo
- grey trousers (no turn-ups) with a black belt
- long or short sleeved light blue shirt
- yellow tie with the FILA logo
- black socks
- black plimsolls

The dress must be a model homologated by FILA. The refereeing body may not wear the name of a sponsor. However, the number on his jacket may include the name of the FILA sponsor.

Article 19 - The referee

a) The referee is responsible for the orderly conduct of the bout on the mat, which he must direct according to the Rules.

b) He must command the respect of the contestants and exercise full authority over them so that they immediately obey his orders and instructions. Similarly, he must conduct the bout without tolerating any irregular and untimely outside interventions.

c) He shall work in close co-operation with the judge and must carry out his duties in supervising the bout while refraining from any impulsive or untimely interference. His whistle shall begin, interrupt and end the bout.

d) The referee shall order the return of the wrestlers to the mat after they have left it, or the continuation of the bout in the standing or "par terre" position (on the mat), with the approval of the judge, or failing that, with the approval of the mat chairman.

e) The referee is required to wear a red wristband on his left arm, and a blue wristband on his right arm. He shall indicate with his fingers the points corresponding to the value of a hold after its execution (if it is valid, if it has been executed within the limits of the mat, and if a wrestler has been put in a danger position, etc.), by raising the arm corresponding to the wrestler who scored.

f) The referee must never hesitate to:

- Interrupt the bout at exactly the right time, neither too soon nor too late.
- Indicate whether a hold executed at the edge of the mat is valid.

- Visibly count the five seconds during which the wrestler is held in a bridge position and award the additional point for this situation.
- Signal and announce TOUCHE (fall) after seeking the agreement of the judge, or if this is not possible, of the mat chairman. In order to determine whether a wrestler has actually been pinned to the mat by both shoulders at the same time, the referee must say the word TOUCHE (fall), raise his hand to secure the agreement of the judge or the mat chairman, strike the mat with his hand and then blow the whistle.

g) The referee must:

- Rapidly and clearly order the position in which wrestling must be resumed, when he sends the wrestlers back to the centre of the mat (their feet must be in the central circle).
- Not stand so close to the wrestlers that he obstructs the view of the judges and the mat chairman, particularly if a fall appears imminent.
- Ensure that the wrestlers do not rest during the bout on the pretence of wiping their bodies, blowing their noses, pretending to be injured, etc. In this case, he must stop the bout and ask for a caution (0) to the wrestler at fault and 1 point to his opponent.
- Be able to change his position from one moment to the next, on the mat or around it, and in particular, immediately fall flat onto his stomach to obtain a better view of an imminent fall.
- Be able to stimulate a passive wrestler without interrupting the bout, by standing in such a way as to prevent the wrestler from leaving the mat.
- Be ready to whistle if the wrestlers come too close to the edge of the mat.
- Not interrupt the bout in Greco-Roman Wrestling in a danger position after 1 minute and 30 seconds.

h) The referee is also required to:

- Pay special attention to the wrestlers' legs in Greco-Roman Wrestling
- Require the wrestlers to remain on the mat until the result of the bout is announced.
- In all cases where agreement is necessary, first ask the opinion of the judge at the edge of the mat facing the mat chairman.
- Proclaim the winner after agreement with the mat chairman after each period and at the end of the bout.

i) The referee requests penalties for violation of the rules or for brutality.

j) The referee, if the mat chairman intervenes, must interrupt the bout and proclaim victory by technical superiority when the wrestlers' scores are 6 points difference in one period. In this situation, he must wait for the action - either an attack or a counter attack - to be complete.

Article 20 - The judge

a) The judge is responsible for all the duties stipulated in the general Rules of wrestling.

b) He must follow the course of the bout very closely without allowing himself to be distracted in any way; he must award points for each action, and

mark them on his score sheet, in agreement with the referee or mat chairman. He must give his opinion in all situations.

c) Following each action, and on the basis of the referee's indications (which he compares with his own evaluation) or, failing this, on the basis of the mat chairman's indications, he records the number of points awarded to the action in question, and enters the results on a scoreboard placed beside him. This scoreboard must be visible to both the spectators and wrestlers.

d) If, during the bout, the judge notices something that he feels he should bring to the referee's attention because the latter was not able to see it or did not notice it (a fall, illegal hold, passive position, etc.), the judge is obliged to do so by raising the bat of the same colour as the singlet of the wrestler in question, even if the referee has not asked for his opinion. In all circumstances, the judge must call the referee's attention to anything that seems to him abnormal or irregular in the course of the bout or in the conduct of the wrestlers.

e) The judge must, moreover, sign the score sheet handed to him upon receipt, and at the end of the bout, must clearly record on the score sheet the result of the bout by distinctly crossing out the name of the loser and writing in the name of the winner.

f) The decisions of the referee and judge are valid and enforceable without the intervention of the mat chairman, if they are in agreement - except for proclamation of victory by technical superiority, in which case the mat chairman is required to give his opinion and in case of consultation or challenge.

g) The judge's score sheet must accurately indicate the time at which a bout ends in the case of victory by a fall, technical superiority, withdrawal, etc.

h) To make it easier for the judge to supervise the bout, particularly in a delicate position, he is authorised to change positions, but only along the edge of the mat over which he has control.

i) He must also indicate by underlining, the last point scored which can determine the winner of the period.

j) Cautions for fleeing the mat, illegal holds, or brutality will be noted by an 'O' in the column of the wrestler at fault.

k) The judge must be very active in clinch situations and help the referee to determine the wrestler at fault in case of an improper execution of the clinch

Article 21 - The mat chairman

a) The mat chairman, whose functions are very important, shall assume all the duties provided for in the Rules of wrestling.

b) He shall co-ordinate the work of the referee and the judge.

c) He shall order the ordered hold when the period ends 0-0 in Free-style and after 1 minute and 30 seconds in Greco-Roman.

d) The chairman verifies and signals the fall (TOUCHE) to the referee.

e) He is obliged to follow the course of the bouts very carefully, without allowing himself to be distracted in any way, and to evaluate the behavior and action of the other officials according to the rules.

f) In the event of any disagreement between the referee and judge, his task is to settle the issue in order to determine the result, the number of points and the falls.

- g)** In no case may the mat chairman be the first to give an opinion. He must wait for the opinion of the referee and judge. He is not entitled to influence the decision.
- h)** The mat chairman's approval must absolutely be sought before granting a fall.
- i)** The mat chairman may decide to interrupt the bout in case of a serious mistake made by the referee.
- j)** He may also interrupt the bout if a serious scoring mistake is made by the referee and judge. In such case, he must ask for a consultation. If the mat chairman does not obtain majority during the consultation, he must stand for either the referee or judge. This consultation does not alter the wrestler's right to challenge.
- k)** During a bout, when the coach considers that a **blatant refereeing mistake** has been made against his wrestler and calls for a challenge, the mat chairman must wait for the action to go to neutral and stop the match. He must review the video evidence at the same time as the referee, judge, and Jury of Appeal. If the refereeing body was right, the mat chairman must make sure that no other challenge will be granted to the wrestler in question during the remaining of the match.

After the single review of the video evidence, the referee gives his decision first, followed by the judge and the mat chairman. If the mat chairman agrees with his two colleagues, the Jury of Appeal does not intervene and the decision is final, except if it notices a blatant misconduct. In such case, the decision of the Jury of Appeal shall be enforced.

Article 22 - The Jury of Appeal

The Jury of Appeal is formed by the FILA President or his substitute and is made up of three (3) persons chosen among the Instructors, the Bureau members, or knowledgeable refereeing people according to the different matches and wrestlers' nationality. There is one Jury of Appeal per mat.

The Jury of Appeal is responsible for controlling that all rules governing a wrestling match have been applied by the refereeing body before the winner of the period or the match can be declared by the mat chairman.

One member of the Jury of Appeal will be appointed as coordinator and will be in charge of announcing the Jury's decisions on behalf of all.

If the Jury of Appeal notices that a serious administrative, timing, or scoring mistake has been made, the coordinator must bring it to the mat chairman's attention and ask for rectification. If the Jury of Appeal notices that the mat chairman did not stop the match further to a challenge request, the coordinator must ask him to do so immediately after the action is completed.

During the video review, the Jury of Appeal will not be allowed to speak with the refereeing body that must make its decision on its own. If the majority of the refereeing body reaches an agreement (the mat chairman's agreement being mandatory, the Jury of Appeal cannot intervene, except in the case of blatant misconduct. In such case, the Jury invites the mat chairman at its table, reviews the disputed action a second time and renders its final decision. No further appeal will be possible.

If the mat chairman does not agree with the referee and the judge, then he must seek the Jury of Appeal's decision and it will be considered final and irrevocable.

Article 23 - Penalties against the officials

The FILA Bureau, which constitutes the supreme jury, shall have the right to take the following disciplinary measures against the official(s) technically at fault:

- 1) Give the official concerned a caution.
- 2) Withdraw the official from the competition.
- 3) Demote the official to a lower category.
- 4) Order a temporary suspension.
- 5) Order a final dismissal.

CHAPTER 5 - THE BOUT

Article 24 - Duration of the bouts

For schoolboys, cadets, juniors, and seniors: three (3) periods of 2 minutes with a 30-second break.

For all the competitions, the timing displayed on the scoreboards will start from 0 to 2 minutes. A light of the same color as the wrestler concerned must indicate the winner of each period, and the result of each period must remain indicated.

At the end of each period, a wrestler is declared the winner. The wrestler winning two periods is declared the match winner. If the victory can be proclaimed after two periods, the third period is withdrawn. The fall stops automatically the match whatever the period.

Freestyle and Female wrestling: The duration of a period is 2 minutes. If at the end of the period, the score is 0-0, a maximum 30-second overtime (clinch) will be carried out.

Greco-Roman Wrestling: The duration of a period is 2 minutes with either 2 minutes of standing wrestling or 1 minute 30 of standing wrestling and 30 seconds of ground wrestling (clinch). No overtime is provided.

Article 25 - Call to the mat

The contestants are called in a loud and clear voice to present themselves on the mat. A contestant cannot be called to compete in a new bout until he has had a rest period of 15 minutes from the time his preceding bout ended.

A delay is granted to any wrestler who does not reply to the first request in the following manner:

- 1) The competitors must be called three times at 30-second intervals. If the wrestler does not come forward after the third call, he will be disqualified and will not be placed.
USAW Modification: see page 66.
- 2) These calls are made in both French and English. (*English only for all USAW domestic events.*)
- 3) His/her opponent will win the bout by default.

Article 26 - Presentation of wrestlers (Not applicable to USAW events)

The following ceremony takes place for each weight category in the finals for first and second places:

- The finalists are presented on the mat. The speaker announces their achievements during the bout.

Article 27 - Start

Before the bout begins, each opponent answers when his name is called and takes his place at the corner of the mat assigned to him. The corner is the same color as the singlet he has been assigned to wear.

The referee, standing in the central circle in the middle of the mat, calls the two wrestlers to his side. He then shakes hands with them and examines their dress, and checks that they are not covered with any greasy or sticky substance. If there is uncertainty, the referee will take the wrestler to the mat chairman. The referee verifies that they are not perspiring, verifies that their hands are bare and that they have a handkerchief.

In Greco-Roman wrestling, the starting position for each period is both wrestlers chest-to-chest, and both feet in the inner (1 m) circle. Once wrestlers are chest-to-chest with heads offset, the referee begins the match.

The wrestlers greet each other, shake hands and, when the referee blows his whistle, they start the bout.

USAW Modification: The athletes must come to the mat fully dressed and prepared to wrestle (must not change matside).

Article 28 - Interrupting the bout

a) If a contestant finds himself forced to interrupt the period because of an injury or because of any other acceptable incident beyond his control, the referee may stop the bout. During such an interruption, the wrestler(s) must stand in their area. They can cover their shoulders with a towel or their dressing gown and receive advice from their coach.

b) If a bout cannot be resumed for medical reasons, the decision is made by the competition doctor in charge, who informs both the coach of the wrestler involved and the mat chairman; the latter then orders that the bout be stopped.

c) Under no circumstances may a contestant take the initiative to interrupt the action himself, by deciding to wrestle in the standing or "par terre" position, or by pulling his opponent back from the edge of the mat to the centre.

d) If an action must be stopped due to one wrestler deliberately injuring his opponent, the wrestler at fault will be cautioned and the injured wrestler will receive 1 point if the injured wrestler can continue. If the injured wrestler cannot continue, and all three officials agree on brutality, the offending wrestler will be disqualified.

e) If a wrestler interrupts the bout without blood or visible injury, 1 point will be awarded to the opponent.

Article 29 - End of the bout

The bout ends either when a fall, a disqualification by injury of one of the opponents is declared, or at the end of the regular time.

A period ends either by technical superiority (6 points difference), or after the execution of a “grand amplitude” 5-point hold whatsoever the score, or after the execution of two 3-point holds whatsoever the score, or in case of an ordered hold in freestyle if the wrestler wins 1 point or more before 30 seconds, or upon expiration of the regular time, signalled by the sound of the gong and the referee’s whistle.

When a wrestler executes a 5-point hold within the regular time, the referee must wait for the possible fall. If his opponent overcomes, the referee must whistle immediately and declare the winner of the period or the match. The second 3-point hold may be followed by an immediate counter-attack which puts opponent in a danger position, the action may end up in a fall.

To win a match by technical superiority, the winner shall win two periods by technical superiority (twice 6 points difference) or two periods with a 5-point hold or one victory with a 5-point hold and one victory by technical superiority (6 points difference) or two periods with two 3-point holds.

If the referee has not heard the gong, the mat chairman must intervene and stop the bout by throwing a soft object on the mat, in order to attract the referee’s attention.

Any action begun at the time when the gong sounds is not recognized and no action performed between the sounds of the gong and the referee’s whistle is valid.

When the bout has ended, the referee stands in the centre of the mat facing the officials’ table. The wrestlers shake hands, stand on either side of the referee and await the decision. They are forbidden to lower the shoulder straps of their singlets before leaving the competition hall.

Immediately after the decision is announced, the wrestlers shake hands with the referee.

Each wrestler must then shake hands with his opponent’s coach. If the above provisions are not observed, the wrestler at fault will be penalized in accordance with the Disciplinary Regulations.

Article 30 - Interrupting and continuing the bout

When the wrestling has been stopped in standing or “par terre” position, it will recommence standing.

Wrestling must be stopped and resumed at the centre of the mat in the standing position if:

- a) one foot entirely touches the protection area
- b) the wrestlers in a hold go into the red zone with three or four feet without executing the hold and stay there
- c) if the bottom wrestler's head entirely touches the protection zone.

If an attacked wrestler takes an illegal action in the "par terre" position, he will receive a caution and 1 or 2 points will be attributed to his opponent. The bout resumes in an ordered "par terre" position, without considering if the wrestler has succeeded or not in his hold.

When a challenge is requested by a coach, the mat chairman interrupts the bout when the action is back to neutral.

Article 31 - Overtime (freestyle and female wrestling)

If at the end of the regular time of a period, the two wrestlers attain 0-0, the referee will stop the bout and order that the bout be resumed in an ordered hold position (article 49).

The extra time period will last a maximum of 30 seconds.

Article 32 - Types of victories

A bout may be won by:

- a) a "fall"
- b) by injury, withdrawal, default, disqualification of the opponent.
- c) by technical superiority
- d) by points (winning two periods by 1 to 5 points difference)

If the wrestler executes a "grande amplitude" 5 points hold, he will be declared the winner of the period whatever the score.

If the wrestler executes two 3-point holds in the period, he will be declared the winner of the period whatsoever the score.

In case of a tie by points (*with USAW clarification*)

To declare the winner, one should see the criterion of (least) amount of cautions, (*highest*) value of holds, and last scored technical point (see layout herewith below).

In case of tie by points, the winner will be declared by successively considering the amount of cautions, the value of the holds, and the last technical point(s) scored (see layout).

Example:

Red Point	Blue Point	Comment	Result
1 1 1	1 1 <u>1</u>	Last technical point scored by the blue wrestler.	The blue wrestler wins
1 2	1 1 <u>1</u>	Last technical point scored by the blue wrestler. The red wrestler has scored a 2 points hold.	The red wrestler wins
1 1 <u>1</u> 0 0	1 1 1 0	Last technical point scored by the red wrestler, but he has 2 cautions, and the blue wrestler has one.	The blue wrestler wins
1 1 1	1 <u>2</u> 0	The blue wrestler has scored a 2 points hold which are the last technical points, but he has one caution.	The red wrestler wins
1 1 <u>1</u> 0	1 2 0	The red wrestler has scored the last technical point. Each of the wrestlers have one caution. The blue wrestler has scored a 2 points hold.	The blue wrestler wins
1 1 1 0 0	1 1 <u>1</u> 0 0	Each of the wrestlers have 2 cautions. The blue wrestler has scored the last technical point.	The blue wrestler wins

However, in order not to penalize the attacking wrestler, if the last point causing an even score is obtained by a hold which gives 2 points to each of the opponent because the attacking wrestler rolls on his shoulders in the execution of the hold without action from his opponent, the victory will be attributed to the attacking wrestler.

A wrestler receiving 3 cautions on the total periods of a match is disqualified.

In Freestyle, if the period ends 0-0, the winner of the period shall be the wrestler who wins the first point during the ordered hold.

Article 33 - The coach

The coach may remain at the foot of the platform or at least two metres from the edge of the mat during the bout. Except for the assistance he is authorised to give to a doctor who is providing medical attention to his wrestler, the coach is strictly forbidden to influence decisions or to insult the referee or judge. He may only speak to the wrestler. The coach does not have the right to give water or any other substance during the pause or during the match.

If these restrictions are not observed, the referee is obliged to ask the mat chairman to present the coach with a 'Yellow' card (caution); if he persists, the mat chairman will present him with a 'Red' card (elimination). The mat chairman may also present the YELLOW or RED card on his own initiative.

As soon as the red card is given, the mat chairman reports to the competition director and the coach shall be eliminated from the competition and may no longer continue his duties. However, the wrestling team involved shall have the right to obtain the services of another coach. The national Federation of the eliminated coach will be penalized following the dispositions of the Disciplinary and Financial Regulations.

USAW Modification: A wrestler may have a maximum of two coaches in his/her corner during competition.

USAW Modification: Certification For all Kids & Cadet* division regional competition, coaches coaching at mat side must be a minimum of USAW Copper Level certified. For Kids National competitions, coaches at mat side must be copper certified. *For the Cadet, FILA Cadet, and Junior Division National Championships and National Dual Championships, all coaches must be minimum Bronze certified. **For Junior regional competitions, all coaches must be Bronze certified.**

Article 34 - The Challenge

The challenge is the action through which the coach is allowed, on behalf of the wrestler, to stop the action and request the refereeing body to watch the video evidence in case of a disagreement with the call. This possibility is only offered during competitions in which the video control is formally established by FILA and the Organizaing Committee.

The coach must request the challenge by throwing a soft object on the mat, immediately after the refereeing body has awarded or refused the points to the contested situation. If the wrestler disagrees with the coach's decision, then the match continues.

Specific Points

- Each wrestler is entitled to one (1) challenge per match. If after reviewing the challenge the refereeing body modifies its decision, then the challenge can be used again during the match.
- If the refereeing body or Jury of Appeal confirms the decision, the wrestler loses the challenge and his opponent will receive 1 technical point.
- The mat chairman will demand to stop the match to review the challenge as soon as the situation on the mat becomes neutral.
- No challenge can be requested in the event of a fall, being understood that the fall must be confirmed by the mat chairman further to the decision of either the referee or the judge.
- No challenge can be requested after the end of the regular time of a period, except if the points are added to the scoreboard after the referee's whistle.
- The coach requesting the challenge must do so from his seat, without stepping on the mat or approaching the judge's or the mat chairman's table.
- During the review of the challenge, no consultation among the refereeing body is permitted.
- After having reviewed the action once, the referee gives his decision first and is immediately followed by the judge who gives his decision from his seat with the material available to him (paddle or electronically). If the mat chairman agrees, there will be no further intervention by the Jury of Appeal.

- If the mat chairman is in disagreement with the referee and the judge, he shall seek the opinion of the Jury of Appeal. In this case, the decision made by the Jury of Appeal and confirmed by the mat chairman is final and cannot be challenged anymore.
- It will not be possible to request a “counter challenge” once a final decision has been made by the refereeing body or Jury of Appeal.
- The challenge is taken into consideration immediately after the coach has raised the white paddle or thrown in the sponge and it will not be possible for him to withdraw it.

Article 35 - Team ranking during individual competitions

The team classification is determined by the first 10 wrestlers who are classified at the competition.

Place in the weight category	Points	Place in the weight category	Points
1st	10	7th	4
2nd	9	8th	3
3rd - 3rd	8	9th	2
5th - 5th	6	10th	1

The application of the above-mentioned table remains invariable, whatever is the number of wrestlers in each category.

In the event of equal classification of several teams, the team having obtained the most first places is placed first, etc.

Article 36 - Ranking system during team competitions

In principle, a team competition takes place according to FILA official weight category, that is 7 categories. If categories have to be doubled for proper reasons to the country system or team’s interest, it is recommended to have always an odd number of categories. Each team may change the wrestlers for each session, as long as they were weighed-in.

If a home-away session takes place in one day, one winner must be declared at the end of the home bout, and one at the end of the away bout. The victory obtained by a wrestler in a match gives 1 point to his team, with no regard to the way the victory has been obtained. This way each match can give a winner with an odd number.

If a competition involves only two teams:

If it is a one day home away session between two teams, and each team wins a match, there are two ranking possibilities to be determined before the beginning of the match.

- a) Having a third match to determine the winning team
- b) Determine the winning team by assessing the following criterion:
 - 1) the most victories by adding the points of the 2 matches
 - 2) the most victories by fall, default/forfeit/disqualification

- 3) the most match victories by technical superiority
- 4) the most period victories by superiority
- 5) the most technical points obtained in all the competition
- 6) the fewest technical points given in all the competition

If a competition involves more than two teams

The same system will apply to determine the winner of the match. The winning team will receive 1 point and the losing one 0 point.

If two teams have an equal number of classification points at the end of the competition, the winner will be determined on bases of the result of their match.

If 3 or more teams have an equal number victories

The following principle will apply to rank the worst team(s):

- The fewest classification points
- The fewest victories by fall, default/forfeit/disqualification
- The fewest match victories by superiority
- The fewest period victories by superiority
- The fewest technical points obtained in all the competition
- The most technical points given in all the competition.

The two remaining teams will be ranked according to the result of their direct match.

USAW Modification: *USAW has established special policies and rules for all domestic Regional and National Dual Team competitions. These are available on page 142.*

CHAPTER 6 - POINTS FOR ACTIONS AND HOLDS

Article 37 - Evaluation of the importance of the action or hold

In order to remove simulation during bouts, when a wrestler tries unsuccessfully to execute a hold and finds himself underneath in a “par terre” position without a move by his opponent, the wrestler above will not be awarded a technical point. Wrestling continues in a “par terre” position without the referee stopping the bout.

However, if, during a hold, the defending wrestler executes a counterattack and is able to bring his opponent to the ground, he will be awarded the point(s) that correspond to the action.

If the attacking wrestler executes a hold on his own bridge, holds this position for a certain amount of time, and then completes his action by placing his opponent in the bridge position as well, he will not be penalized. Only the attacking wrestler will be awarded the points, as he will have completed the action in a hold that involved risks.

However, if the offensive wrestler is blocked under control in the bridge position or by a counteraction by his opponent, it is clear that points will be awarded to the latter wrestler.

Furthermore, the wrestler on whom a hold was initiated may only be awarded points if, by his own action, he has:

- a) brought the offensive wrestler to the ground
- b) conducted the action on a continuous basis
- c) succeeded in controlling the offensive wrestler by blocking him in a bridge position, that is, in a position considered completed
- d) The referee must wait for the end of each situation prior to awarding the point values earned by each wrestler.
- e) In cases where the wrestlers' actions lead them to change from one position to another, the points for all the actions are awarded according to their value.
- f) The instantaneous fall does not exist (article 44). If the wrestler falls instantly from a standing position following a move by his opponent, the attacker receives three points. If the wrestler falls instantly during his own move, his opponent receives two points. When wrestling in the "par terre" position when the wrestler is in the situation of instant fall, his opponent receives two points.
- g) Rolling from one shoulder to the other using the elbows in the bridge position, and vice-versa, is considered to be only one action.
- h) A hold must not be considered to be a new action until the competitors return to the initial position.
- i) The referee will indicate the points. If the judge agrees, he will raise the bat bearing the colour and value in question (1, 2, 3 or 5 points). In the event of any disagreement between the referee and judge, the mat chairman must make a decision in favour of one or the other of the wrestlers; he is not allowed to give a different opinion.
- j) In the event of a fall that occurs at the end of regulation time, only the sound of the gong (and not the referee's whistle) is valid.
- k) At the end of a period, any hold is valid if it was completed before the gong sounded. In no event may a hold finished after the sound of the gong be counted.

Article 38 - Danger position

A wrestler shall be considered in the 'danger position' when the line of his back (or the line of his shoulders) vertically or in parallel with the mat, forms an angle of less than 90 degrees to the said mat and when he resists with the upper part of his body to avoid a 'fall.' (See definition of 'fall.')

The 'danger position' occurs when:

- a) the defending wrestler assumes the bridge position to avoid being pinned
- b) the defending wrestler, with his back toward the mat, supports himself on one or both elbows to avoid having his shoulders forced onto the mat

c) the wrestler has one shoulder in contact with the mat and at the same time exceeds the 90 degree vertical line with the other shoulder (acute angle)

d) the wrestler finds himself in the 'instantaneous fall' position, that is, when he is on both shoulders for less than one second

e) the wrestler rolls on his shoulders

The 'danger position' no longer exists when the wrestler exceeds the 90 degree vertical line with his chest and stomach facing the mat.

If the mat and the competitor's back form a 90 degree angle only, this cannot yet be considered a 'danger position' (the neutral point).

Article 39 - Recording the points

The judge marks the points obtained for the actions and holds executed by the wrestlers on a score sheet, as each action is performed during the bout.

The points of the action bringing about a fall are to be noted on the score sheet by a circle.

The caution for fleeing the mat, fleeing a hold, refusal to start, illegal hold and brutality shall be noted by (0). After each caution (0) the opponent will automatically receive one or two technical points, depending on the gravity of the infraction.

In the case of a tie in points, the last technical point scored shall be underlined.

Article 40 - High amplitude throw

Any action or hold by a wrestler in the standing position is deemed to be a 'grande amplitude' throw when:

- it causes his opponent to lose all contact with the ground, controls him, makes him describe a broadly sweeping curve in the air, and brings him to the ground in a direct and immediate danger position
- in the "par terre" position, any complete lift from the ground executed by the attacking wrestler, whether the attacked wrestler lands belly down (3 points) or in a danger position (5 points), is also considered a grand amplitude throw

N.B. If the wrestler executing a grand amplitude hold himself touches the mat with both shoulders, he receives 3 or 5 points and his opponent receives two points, due to the instantaneous fall in the execution of the throw.

Article 41 - Value assigned to actions and holds

1 point:

- to the wrestler who brings his opponent to the ground by passing behind him, and while in this position holding him down with control

- (three points of contact: two arms and one knee or two knees and one arm or the head or two arms and the head)
- to the wrestler who applies a correct hold while standing on the mat or in the “par terre” position but who does not place his opponent in danger
 - to the wrestler who overcomes, holds and controls his opponent by passing behind him
 - to the wrestler who blocks his opponent on one or two outstretched arms, his back facing the mat
 - to the wrestler who is prevented from completing a hold because his opponent is maintaining an irregular hold, but who finally succeeds in completing the hold
 - to the attacking wrestler whose opponent flees the hold, the mat, refuses to start, commits illegal actions or acts of brutality
 - to the wrestler who holds his opponent in a position of danger for five seconds or longer
 - to the wrestler whose opponent goes in the protection zone with one entire foot (standing position)
 - to the wrestler whose opponent regularly refuses to take an ordered hold in free style
 - to the ordered wrestler in par terre position in greco style whose opponent has not been able to score any technical point during the regulatory 30 seconds
 - all the stops of bout by injury without bleeding or any visible injury are penalized by 1 point to the opponent
 - to the wrestler whose opponent refuses correct ordered hold in GR ordered hold
 - to the wrestler whose opponent requested a challenge if initial decision is confirmed
 - to the wrestler who did not get scored on during overtime in freestyle wrestling

2 points:

- to the wrestler who applies a correct hold while wrestling in the “par terre” position and places his opponent in a position of danger or in an instantaneous fall position
- to the attacking wrestler whose opponent rolls onto his shoulders
- to the attacking wrestler whose opponent flees the hold by jumping off the mat in a position of danger
- to the attacking wrestler whose opponent engages in an illegal hold which prevents him from completing a hold or a fall he had initiated
- to the defending wrestler if the attacking wrestler goes into the instantaneous fall position or rolls onto his shoulders in executing a hold
- to the wrestler who blocks his opponent in the execution of a hold from the standing position, in a position of danger
- to the top wrestler whose opponent refuses correct par terre position in Greco-Roman ordered hold

3 points:

- to the wrestler performing a hold in a standing position, which brings his opponent into a danger position by direct projection over a short amplitude
- for any hold executed by raising a wrestler from the ground, over a short amplitude, even if one or both of the attacking wrestler's knees are on the ground, provided that the defending wrestler is immediately placed in a danger position
- to the wrestler who executes a grande amplitude hold which does not place the opponent in a direct and immediate danger position

NB. If, in performing a hold, the defending wrestler maintains contact with the mat with one of his hands, but is immediately placed in a danger position, the attacking wrestler will receive three points.

5 points:

- all high amplitude throws executed in a standing position which bring the defending wrestler to a direct and immediate danger position
- the hold executed by a wrestler in the "par terre" position who completely lifts his opponent off the ground with the execution of a grande amplitude throw which projects the opponent into a direct and immediate danger position

Article 42 - Decision and vote

a) The referee shall indicate his decision by raising his arm and clearly showing the points with his fingers. If the referee and judge agree, the decision is announced.

b) The mat chairman is not entitled to influence or change a decision if the referee and judge are in agreement except if he calls for a consultation or after a challenge.

c) If a vote is taken, the judge and mat chairman must indicate their votes using bats or an electric score board.

There are 11 bats, painted different colours: blue, red and white, as follows:

- one white
- five red, four of which are numbered 1, 2, 3, 5 to indicate the points and one of which is an unmarked bat intended for cautions and to attract attention to the wrestler concerned
- five blue bats, four of which are numbered as the red bats, with one bat unmarked

They must be kept within easy reach of those who are to use them. Under no circumstances may the judge abstain from voting. He must express his decision clearly, leaving no room for ambiguity.

In case of disagreement, the mat chairman makes the decision. This decision, in which he must decide between the opposite opinions of the referee and judge, obliges the mat chairman to vote in all cases for one or the other views given.

d) If the period lasts until the end of the allotted time, the mat

chairman's score sheet will be taken into consideration when designating the winner. The public scoreboard must conform to the mat chairman's score sheet at all times during the bout.

If there is a difference of 1 or more points between the judge's and mat chairman's score sheets, only the score on the mat chairman's score sheet will be considered.

USAW Modification: MAT CHAIRPERSON - For Junior, Cadet, and Kids Division events, the Mat Chairperson may call a conference of the officiating team if an error has been made. This may be done even if both the judge and referee agreed on the call or situation in question.

For sample bout sheet, see page 139.

Article 43 - Decision table

Assignment of points

When observing a wrestling action, the referee and judge award the points, cautions, indicated below which, in each of the cases put forward, provides the following result:

R = red wrestler B = blue wrestler O = zero points

Position of the official

Referee	Judge	Mat chairman	Official result	Observations
1R	1R	-	1R	In these examples the judge and referee being in agreement, the mat chairman does not intervene except for serious fault
2B	2B	-	2B	
3R	3R	-	3R	
5R	5R	-	5R	

Referee	Judge	Mat chairman	Official result	Observations
1R	0	0	0	In these examples the judge and the referee being in disagreement, the mat chairman intervenes and the principle of majority applies
1B	1R	1R	1R	
2R	1R	2R	2R	
2B	0	2B	2B	
3R	2R	2R	2R	
3B	1R	3B	3B	

In the event of any flagrant violation of the Rules, the mat chairman must call for a consultation.

At the end of each period, the score starts from zero for the following period.

CHAPTER 7 - CLASSIFICATION POINTS AWARDED AFTER A BOUT

Article 44 - Classification points

The classification points awarded to a wrestler shall determine his final ranking.

5 points for the winner and 0 for the loser:

- victory by fall (with or without technical point for the loser)
- injury
- withdrawal, forfeit (see page 66 for USAW Modification default)
- disqualification
- **USAW Modification: For Cadet & Junior Nationals - failure to make weight, if he/she is eliminated on the 2nd day weigh-in.**

4 points for the winner and 0 for the loser:

- victory by technical superiority in both periods (6 points difference, 5-point hold or two 3-point holds), with the loser scoring no technical points

4 points for the winner and 1 for the loser:

- victory by technical superiority in both periods (6 points difference, 5-point hold or two 3-point holds) with loser scoring technical points

3 points for the winner and 0 point for the loser:

- when out of three periods, the wrestler wins two periods of 1 to 5 points and the loser scoring no point

3 points for the winner and 1 point for the loser:

- when during at least one period the bout ends by a victory by points during regular time or by an ordered hold and the loser scoring one or several technical points.

0 point for the red wrestler and 0 point for the blue wrestler

- in case both wrestlers have been disqualified due to infraction to the rules.

Article 45 -The fall

When the defensive wrestler is held by his opponent with his two shoulders against the mat for a sufficient time to allow the referee to observe the total control of the fall, the resulting manœuvre is considered to be a fall. For a fall at the edge of the mat to be recognized, the opponent's shoulders must be completely in the red zone and the head must not touch the protection area.

A fall in the protection area is not valid.

If the wrestler is pinned on both shoulders as a consequence of a rule infringement or an illegal hold for which he is responsible, the fall will be considered valid for his opponent.

The fall observed by the referee will be valid if confirmed by the mat chairman. If the referee does not indicate the fall, and if the fall is valid, it may be announced with the consent of the judge and mat chairman.

Consequently, to be observed and recognized, the fall must be clearly maintained. The two shoulders of the wrestler in question must be simultaneously touching the mat during the short period of stoppage specified in the first paragraph, even in the case of a standing rear body lock and lift. In all cases, the referee will strike the mat only after he has obtained confirmation from the judge or, failing this, from the mat chairman. The referee will then blow his whistle in order to end the bout.

It will not be possible to request any challenge in case of a fall, being understood that the fall must be validated by the mat chairman following the judge or referee's decision.

USAW Modification: *The time required for a fall in all Kids Division competition is two seconds.*

Article 46 - Technical superiority

Except for the fall, default, disqualification, the bout of one period must be stopped before the end of regular time regardless of the score when :

- there are 6 points difference between the wrestlers
- a wrestler has scored two 3-point holds
- a wrestler has scored one 5-point hold

The bout may not be interrupted to declare the winner by technical superiority until the action is completed (see article 29).

The mat chairman signals the referee when the difference of six points has been attained. The referee shall declare the winner after consulting with members of the officiating team, for a period or for the match (in which the wrestler won two periods by superiority).

CHAPTER 8 - NEGATIVE WRESTLING

Article 47 - "Par terre" position during the bout

If one of the wrestlers brings his opponent to the ground during the match, wrestling continues in the "par terre" position and the wrestler underneath may counter his opponent's efforts, stand up or carry out counter-attacks of his choice.

If a wrestler brings his opponent to the ground and owing to good defensive action by the attacked wrestler is unable to initiate an action, the referee stops the bout after a reasonable period of time and has the wrestlers resume the bout in a standing position.

The attacking wrestler is forbidden to resume the bout after ATTENTION is given by jumping off his opponent. If he does so, the referee must give him a caution, give 1 point to his opponent, and ask the wrestler in a "par terre" position to stand up again.

The wrestler on top has no right to interrupt the bout nor to request that wrestling resume in a standing position.

Ordering of "par terre" position

The initial position of wrestlers in "par terre" position before the referee blows his whistle is as follows:

The wrestler ordered in the "par terre" position must have knees and

hands in the centre circle. Distance between his hands and knees shall be at least 20 centimeters. Arms shall be stretched out, feet shall not be crossed, and the superior part of the legs shall be stretched out forming a 90° degree angle with the mat.

The top position wrestler is placed behind his opponent, hands on his shoulders. He can be in a standing position, or have a knee on the floor.

Article 48 - Red zone

The red zone is provided for the purpose of detecting the passive wrestler; it is also intended to help eliminate systematic wrestling on the edge of the mat and any departures from the wrestling area.

- any hold or action begun on the central wrestling area and ending within that zone are valid including position of danger, counterattack and fall.
- any hold or counter attack begun in the standing position on the central wrestling area of the mat (apart from the red zone) is good, regardless of the place where it finishes (wrestling area, red zone or protection area).
- however, if it ends in the protection area, the bout is stopped and the wrestlers are returned to the centre of the mat. In the standing position, points will be awarded according to the value of the hold.
- a fall in the protection area is not valid. The bout must be interrupted and the wrestlers returned in standing position to the centre of the mat because the hold ended off the mat.
- in a case where the attacking wrestler executing the hold arrives in a fall position in the protection zone, the bout shall be stopped and his opponent shall receive two points. The bout shall be resumed in the centre of the mat, in standing position.
- In the execution of their started holds and actions, and which have begun on the central surface of the mat, the wrestlers can enter the red zone with three or four feet and continue their actions or holds in all directions, provided that nothing interrupt the execution of their hold (pushing, blocking, pulling).
- an action or a hold may not be commenced in a standing position in the red zone, except under the strict condition that the wrestlers engaged in the hold have only two feet in the zone. In this case, the referee will tolerate the situation for a limited period of time, waiting for the hold to be developed.
- if the wrestlers interrupt their action in the red zone and stay there or if without any action they place two, three or four feet there, the referee interrupts the bout and brings the wrestlers back to the centre, the bout resumes in standing position.
- in all cases, in standing position, if one of the attacking wrestler's foot is in the protection area, that is outside the red zone, the referee interrupts the bout.
- when the defending wrestler's foot is in the protection area, but the attacking wrestler carries out a hold without interruption, the hold is good. If the attacking wrestler does not carry out the hold, the referee interrupts the bout.
- when the defending wrestler places one of his foot in the red zone, the referee must call 'ZONE' in a loud voice. Upon hearing this word, the

wrestlers must endeavor to return towards the centre of the mat without interrupting their action.

- in wrestling in “par terre” position, any action, hold or counterattack executed from or in the red zone is good, even if it ends in the protection area.
- the referee and judge will award points for all actions initiated in “par terre” position in the red zone and executed in the protection area. However, the bout will be interrupted and the wrestlers returned to the centre in a standing position.
- in wrestling in “par terre” position, the attacking wrestler may continue his action if he moves out of the zone while executing the hold, provided that the shoulders and head of his opponent are within the zone. In this case, even four legs may be off the mat.

Article 49 - Ordered hold

The ordered hold is different in Freestyle and Greco-Roman wrestling because it has two different functions.

The ordered hold in freestyle

It determines the winner of a period ending 0-0 at the end of the 2 minute period. The duration is 30 seconds maximum. The first technical point scored will determine the winner.

The contestant who will have the advantage to take the ordered hold will be designated by a draw.

The contestant who loses by drawing must advance one leg in the middle of the central circle and the other one outside of the central circle.

The contestant who wins the draw must indicate to the referee the leg his opponent must put in the middle of the central circle: the right or the left leg.

The winner of the draw of lots grabs the leg of his opponent (between knee and middle part of upper leg) with both of his arms around this leg in the position he wishes. His head must be placed on the outside of his thigh.

The top position contestant must place both of his hands on the shoulders of his opponent.

The referee whistles when the position is correct and the wrestling can start.

The first point scored interrupts the match and determines the winner.

At the end of the 30 seconds period, if the wrestler who had the advantage to take the hold has not scored any technical points, his opponent will obtain one technical point and be declared the winner of the period.

The ordered hold in Greco-Roman style

A period of Greco-Roman wrestling consists of either 2 minutes of standing wrestling or 1 minute 30 seconds wrestling in a standing position and 30 seconds wrestling in a par terre position. Wrestling starts in the center of the mat in a standing position. The wrestlers can carry out any possible actions.

If none of the wrestlers has scored technical points after 1 minute and 30 seconds, there will be an ordered hold.

Period 1 Red on top
 Period 2 Blue on top
 Period 3 If each wrestler won a period and the third period is tied 0-0, the choice of the position (top or bottom), will be given to the wrestler who scored the highest number of technical points in the first two periods (added together). If the two wrestlers scored the same number of technical points, the following criteria will be taken into consideration:

1. Least number of cautions
2. Highest value of the points
3. Draw

When the clinch is ordered after a score of 0-0, the top wrestler has to score to win the period. If the top wrestler does not score any point(s), the bottom wrestler will receive 1 point and win the period.

The wrestler who takes the clinch will be able to choose between the side position and lift or the back position, standing or one knee to the mat, with his hands resting on the opponent's shoulders. At the end of the 2 minutes, the winner of the period is declared.

If no technical point is scored during the 30 seconds, 1 point will be awarded to the bottom wrestler and he will be declared the winner of the match.

Examples:

	RED	BLUE
Period 1	3	---
Period 2	1	2
Period 3	---	---

The red wrestler gets to choose the position (top or bottom). If the top wrestler does not score, 1 point will be awarded to the bottom wrestler who will win the match.

	RED	BLUE
Period 1	3	---
Period 2	---	3
Period 3	---	---

The referee draws a ball and the wrestler who gets picked takes the top position. If the top wrestler does not score, 1 point will be awarded to the bottom wrestler who will win the match.

	RED	BLUE
Period 1	2-0	11
Period 2	3	111
Period 3	---	---

The blue wrestler gets to choose the position (top or bottom). If the top wrestler does not score, 1 point will be awarded to the bottom wrestler who will win the match.

	RED	BLUE
Period 1	2	1
Period 2	1	2
Period 3	---	---

The referee draws a ball and the wrestler who gets picked takes the top position. If the top wrestler does not score, 1 point will be awarded to the bottom wrestler who will win the match.

The wrestler in the “par terre” position must have knees and hands in the centre circle. Distance between his hands and knees shall be at least 20 centimetres and the distance between the hands shall be a maximum of 30 centimetres. Arms shall be stretched out, feet shall not be crossed, and the superior part of the legs shall be stretched out forming a 90° degree angle with the mat, according to the following layout. The wrestler who takes the ordered position can choose between the side position and lift or the back position, standing or one knee to the mat, with his hands resting on the opponent’s shoulders.

During the Greco-Roman clinch situation, each infraction by the bottom wrestler will be penalized by a caution and 1 or 2 points to his opponent. The bout will be started again “par terre” and in the clinch position. If the infraction occurs by bottom wrestler after the clinch hold was broken, the wrestler at fault will be penalized by a caution and 1 or 2 points to his opponent, the bout will start again in par terre position of the ordered “mise à terre.” In case both wrestlers come in standing position after the clinch hold is broken, and one wrestler avoids an attack by making a fault, he will be penalized by a caution, and 1 or 2 points to his opponent and the bout must continue in standing position until the end of the 30 seconds.

Layout for the ordered hold position in Greco-Roman

In order to clarify the position of the wrestlers during the ordered hold in Greco-Roman and to avoid penalty, a correct position scheme must be drawn on the mat, as detailed below.

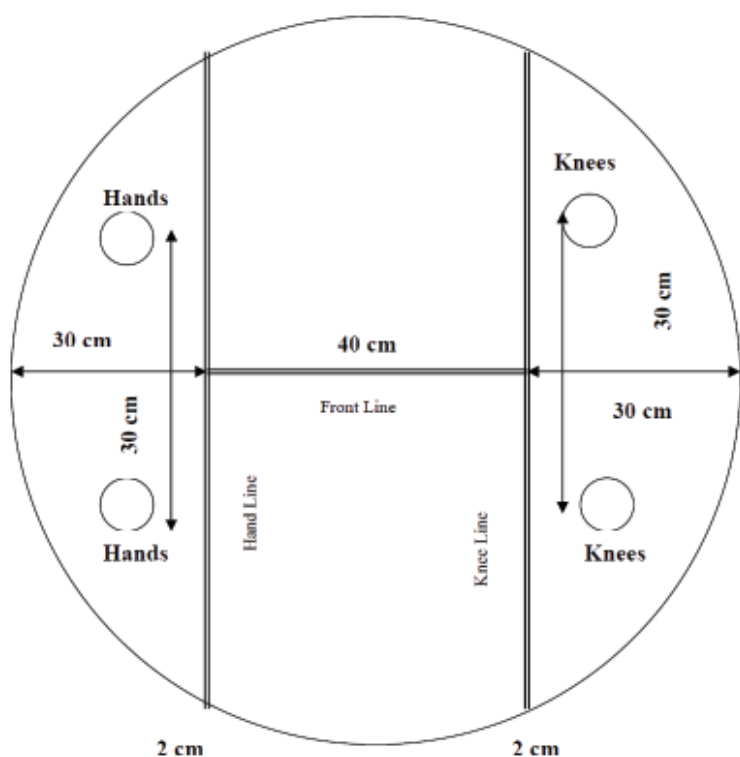

Possibility of position of one foot or two feet on the line. The foot/feet must not go beyond the line.

In order to execute the ordered hold, the top wrestler grabs the wrestler in the "par terre" position by his waist, with his head towards his opponent's back, and executes a reverse body-lock, hand on hand or hand in hand. The wrestler who takes the hold can be in a standing position or have one knee on the mat. **USAW Modification:** For all age groups 14 years and younger the athlete executing the reverse body lock in the clinch situation must have both knees on the mat.

At the referee's whistle, he must take hold at once, with both arms and without simulating. In any case, the wrestler cannot push his opponent with his leg or make gestures towards the referee regarding his opponent's position. If the attacking wrestler simulates or pushes with his legs, the referee must stop the match and warn the wrestler at fault with ATTENTION. If the attacker repeats the violation a second time, the referee must apply the proper sanction by awarding a caution and 1 point to the opponent. Wrestling resumes in standing position.

Once the hold is executed, the referee whistles and the top wrestler can execute the hold. His opponent can start defending himself. During these 30 seconds, both wrestlers can execute all possible actions, in a standing or a "par terre" position.

All the Greco-Roman periods take place in the same manner.

Special Situations

- If the bottom wrestler refuses to correctly apply the ordered hold, the referee will strongly warn him first by using the word ATTENTION. If the wrestler doesn't obey at the second referee's warning, he will receive a caution and 2 points will be awarded to his opponent. A new ordered hold will then be ordered for the same wrestler.
- If at the end of the 1 minute and 30 seconds, a wrestler is placed in a danger fall position, the referee will not stop the match, and the mandatory par terre position will be eliminated.
- If the top wrestler refuses to apply the ordered hold, the referee will strongly warn him first by using the word ATTENTION. If the wrestler doesn't obey the second referee's warning, he will receive a caution and 1 point will be awarded to his opponent. He will then lose the right to place his opponent in the ordered hold par terre position and wrestling will continue in a standing position for the last 30 seconds.
- In case both wrestlers come into the standing position during the 30 seconds of the ordered hold, the bout will continue in the standing position until the end of the 30 seconds.
- The same procedure will apply for all age categories.

CHAPTER 9 - PROHIBITIONS AND ILLEGAL HOLDS

Article 50 - General prohibitions

Wrestlers are forbidden to:

- pull the hair, ears, genitals, pinch the skin, bite, twist fingers or toes, etc. and generally, to perform actions, gestures or holds with the intention of torturing the opponent or making him suffer to force him to withdraw
- kick, head-butt, strangle, push, apply holds that may endanger the opponent's life or cause a fracture or dislocation of limbs, tread on the feet of the opponent or touch his face between the eyebrows and the line of the mouth
- thrust the elbow or knee into the opponent's abdomen or stomach, carry out any twisting action which is likely to cause suffering, or hold the opponent by his singlet
- cling to or grasp the mat
- talk during the bout
- seize the sole of the opponent's foot (only seizing the upper part of the foot or the heel is permitted)
- agree the match result between themselves

Article 51 - Fleeing a hold

Fleeing a hold occurs when the defending wrestler openly refuses contact in order to prevent his opponent from executing or initiating a hold. These situations arise in both the standing and "par terre" positions. They may occur in the central wrestling area or from the central wrestling area to the red zone. Wrestling action, either standing or par terre, does not need to be stopped in order for ATTENTION to be given.

Fleeing a hold shall be penalized in the same way as fleeing the mat, that is:

- ATTENTION will be given (with or without stopping the match)
- one caution against the wrestler at fault (0)
- one point to the opponent

Fleeing hold on the ground in Greco-Roman Wrestling

When a wrestler is on the ground following an action by his opponent and he then jumps forward to prevent his being caught for a hold, he puts his opponent in the position of committing an illegal hold - holding the thighs of the "escaping" wrestler, will be considered as a fleeing of a hold.

The referee must not allow this situation which is a fleeing the hold offence by the fleeing wrestler. He must therefore be very clear and precise in the manner in which he deals with this offense.

- The first time that the wrestler on the ground jumps forward to avoid being caught by his opponent, the referee must warn aloud "attention, no jump."
- The second time, the referee must request a caution and 1 point for fleeing the hold, stop the match following agreement by the judge and the match chairman, make the wrestlers stand up, signal the offense and restart the match in standing position.

This method is valid for penalizing fleeing the hold when the wrestler jumps forward. However, the defense of moving laterally to avoid a hold is authorized and should not be sanctioned.

The wrestler who is dominated on the ground in Greco-Roman does not have the right to bend or raise either or both of his legs to prevent a hold being executed.

If a dominated wrestler on the ground uses his legs as a defense, he will receive a caution (O) and his opponent two points.

Standing in Freestyle and Greco-Roman Wrestling

The wrestler who refuses contact in Freestyle and Greco-Roman wrestling or who gesticulates to simulate contact must be sanctioned as he is cheating and going against the spirit of wrestling.

The referee must give an amicable verbal caution the first time, saying "red contact" or "blue contact". If the wrestler still refuses contact, he will be penalized with a caution and his opponent will receive one point for fleeing the hold. After the referees stops the bout, wrestling resumes in a standing position.

Article 52 - Fleeing the mat

When a wrestler flees the mat, from either a standing or "par terre" position, a caution shall immediately be issued against the wrestler at fault.

The following points shall be awarded to the attacking wrestler:

Fleeing the mat

- one point + one caution against the opponent (0)

Fleeing the mat in a position of danger:

- two points + caution against the opponent (0)

All points for fleeing the mat are considered technical points. Also, all fleeing the mat in standing position gives one point to the opponent, whether the wrestler has been pushed outside or not.

On the other hand, the action which consists of voluntarily carrying the opponent out of the mat will give 1 caution to the carrying wrestler and 1 point to his opponent.

The standing position consisting of voluntarily maintain the opponent to a distance or to break contact will penalize the faulty wrestler of 1 caution and 1 point will be attributed to his opponent, just like for the hold escape.

Article 53 - Illegal holds

The following holds and actions are illegal and strictly prohibited:

- throat hold
- twisting of arms more than 90 degrees
- arm lock applied to the forearm
- holding the head or neck with two hands, as well as all situations and positions of strangulation
- double Nelson, if not executed from the side without the use of the legs on any part of the opponent's body
- bringing the opponent's arm behind his back and at the same time applying pressure to it in a position where the forearm forms an acute angle
- executing a hold by stretching the opponent's spinal column
- chancery hold with one or two hands in any direction whatsoever
- the only holds allowed are with the head and one arm
- in standing holds executed from behind when the opponent is head down (reverse waist hold), the fall must be executed only to the side and never from top to bottom (header)
- in executing a hold, only one arm may be used to hold the opponent's head or neck
- lifting the opponent who is in a bridge position and then to throw him/her onto the mat (severe impact on the ground); that is, the bridge must be forced down
- breaking the bridge by pushing in the direction of the head
- generally, if the attacking wrestler is found to have violated the Rules during the execution of a hold, the action in question shall be completely void and on the first offence, the referee shall give an "attention" to the attacking wrestler at fault. If the attacker repeats his violation, he will be punished by a caution and one point will be awarded to his opponent.
- if a defending wrestler, by an illegal action, prevents his opponent from developing his hold, the defending wrestler will be cautioned. His opponent will receive two points.

Prohibited holds for female wrestling

All double Nelson holds in the “par terre” or standing position are forbidden in female wrestling.

Prohibited holds for schoolboys and cadets (includes USAW Cadets and FILA Cadets)

To protect the health of young wrestlers, the following holds are considered illegal and prohibited for the schoolboy and cadet categories:

- Double Nelson from both the front and side
- In freestyle, a leg hook on the opponent’s leg, in addition to the double Nelson

Referee’s duty towards the competitor committing a violation:

If the attacking wrestler can carry out the action in spite of an illegal hold of the defending wrestler:

- stop the violation
- ask for a caution
- give 1 point to the opponent
- give the value corresponding to the hold to his opponent
- stop the match
- resume wrestling in the standing position

If the attacking wrestler cannot carry out his action because of an illegal hold of the defending wrestler

- stop the match and ask for a caution
- give 2 points to his opponent
- resume wrestling in the position where the infraction occurred

Article 54 - Special prohibitions

- In Greco-Roman wrestling, it is forbidden to grasp the opponent below the hips and to squeeze him with the legs. All pushing, pressing or ‘lifting’ by means of contact with the legs on any part of the body of the opponent is also strictly forbidden.
- In Greco-Roman wrestling, unlike in freestyle wrestling, it is necessary to accompany the opponent to the ground and to stay in contact with him in order for a hold to be valid.
- In Freestyle wrestling, a scissor-lock with the feet crossed on the head, neck or body is forbidden.

Article 55 - Consequences affecting the bout

The illegal hold of the attacked wrestler shall be stopped by the referee without interrupting the hold if possible. If there is no danger, the

referee allows the development of the hold and waits for the result. He then stops the match, gives the points and a caution to the wrestler at fault.

If the hold begins properly and then becomes illegal, the hold should be evaluated up until the beginning of the infraction, then the match should be stopped and wrestling should be made to continue in a standing position with the attacking wrestler receiving an amicable caution. If the wrestler attacks again with an illegal hold, the referee will stop the match, give a caution (0) to the wrestler at fault, one point to his opponent.

In all cases, in the event of any willful butting with the head or any other brutality, the wrestler at fault may be eliminated immediately from the bout by a unanimous decision of the officiating team, or disqualified from the competition and placed last with a comment "eliminated for brutality".

USAW Modifications/Clarification: DISQUALIFICATION - *After three cautions for fleeing the mat, fleeing a hold, incorrect starting position and/or illegal holds, the wrestler at fault will be disqualified. All cautions will result in technical points being awarded to the offended wrestler.*

Cautions are applied as follows:

- *Fleeing the mat: A caution is charged against the wrestler at fault, 1 point awarded to the attacking wrestler.*
- *Fleeing the mat in a position of danger: A caution is charged against the wrestler at fault, 2 points awarded to the attacking wrestler.*
- *Fleeing a hold: A caution is charged against the wrestler at fault, 1 point awarded to the attacking wrestler.*
- *Illegal hold which does not prevent a hold from scoring: Points for the action are scored, a caution is charged against the wrestler at fault, 1 point awarded to the attacking wrestler.*
- *Illegal hold which does prevent a hold from scoring: A caution is charged against the wrestler at fault, 2 points awarded to the attacking wrestler.*

Disqualification for misconduct or brutality may be penalized by loss of the bout and/or removal from the entire competition at the discretion of the officiating team. For loss of the bout, two of the three officials must agree on the penalty. For removal from the competition, the officiating team must all agree on the penalty. A recommendation for disqualification from the tournament shall be reviewed by the protest committee.

CHAPTER 10 - THE PROTEST

Article 56 - The protest

No protest may be lodged at the end of a match. Under no circumstances may the result of a match be modified after victory has been declared on the mat.

If the FILA President or the responsible person for refereeing notes that the refereeing body have abused their power to modify a match result, they can examine the video and, with the agreement of the FILA Bureau, sanction those responsible as laid down in the provisions of the Regulations for International Refereeing Bodies.

USA Wrestling Protest Procedures:

PROTEST PROCEDURES

A written protest may be submitted when a flagrant violation of the rules of wrestling or an irregular situation is noted. The protest must be filed in writing on an official protest form available from the chief pairing master.

On any protest involving application or interpretation of the rules, the mat chairman must be notified immediately after the end of the bout that a protest is imminent. The written protest must be filed no later than 30 minutes after the end of the bout.

The protest must be submitted to the chief pairing master, who shall forward it to the committee. Each protest must be accompanied by a fee of **\$100**, which will be refunded if the protest is upheld.

In the cases of video review, the FILA protest procedures shall apply, which may be modified by USAW. Only USA Wrestling official authorized video footage may be used in any video review.

These rules are subject to change as determined by the appropriate USAW Committee(s) and Board of Directors.

A protest may be accepted and examined when:

- There has been a flagrant violation of the rules.
- There has been a timing error, during which the score of the bout changed.
- Two wrestlers have arrived at a prior agreement regarding the outcome of their bout, to influence the classification of an opponent.
- The judge and referee have awarded points in a unanimous manner and the mat chairman has changed their decision.
- Points are entered in inverse order on the judge's and mat chairman's score sheets, by error, or
- Points have been awarded by majority vote of the officiating team and, by error, these points have not been entered on the score sheets.

A protest may not be accepted nor examined when:

- It concerns the officials' judgment.
- It concerns disqualification of one or both wrestlers for cautions, brutality or violation of the rule.
- It concerns a period in which a fall has been called and confirmed, unless the period/match should have been ended prior to the fall occurring (i.e.: technical superiority previously occurred).
- The outcome of the protest will not change the winner of the period or match.

If the protest is accepted, it shall be examined by the protest committee which makes the final decision. After a decision is reached, the party filing the protest shall be provided a written explanation of the ruling. If the protest is upheld, the other party also shall receive a copy.

The general rule is that the evaluation of any protest by the tournament committee (see page 62) should provide a clear winner. Due to the FILA rule, regarding the way the bout is conducted in terms of periods, the rules for

protesting a period of a bout are as follows: a bout may only be protested at the conclusion of the entire bout -- not at the end of any given period. If, due to a flagrant violation of the rules or an irregular situation during any one period, a protest may be filed regarding that period in question if the decision of the protest may affect the determination of the winner of the bout. If the protest committee is unable to declare a clear winner of the period in protest, after a mandatory 15-minute rest period, the wrestlers will be reassigned to a mat and the particular period in protest will be re-wrestled. The results of this re-wrestled period are final and shall be accepted as the official result. The outcome of this re-wrestled period shall be considered in determining the status of the bout.

The score sheet signed by the mat chairman and by the winning wrestler shall be accepted as the official result, even if it differs from the visual scoreboard, unless — in consideration of a protest — the committee determines that a rule was improperly applied.

If the scoring totals shown on the mat chairman's score sheet differ from the actual totals of the individual points recorded, through an error in addition, the recording of individual scoring moves shall be considered official and the totals shall be corrected by the chief pairing master upon discovery of the error.

Questions concerning errors in recording of results, assignment of classification points and/or improper pairing of the contestants may be addressed to the chief pairing master without the filing of a written protest. Anyone bringing a question to the pairing officials should know the contestant's draw number of the wrestler involved.

When a wrestler is disqualified from a bout or from the event for brutality or flagrant misconduct, such action shall be subject to automatic review by the committee without the filing of a formal protest and the use of official USA Wrestling video maybe authorized.

Under no circumstances shall the use of video tapes or films of a bout be considered or shown in the evaluation of any protest except as noted above or when USAW has provided for the video review of bouts as determined by the Sports Committees and approved by the USAW Executive Committee.

In the use of video review at any USAW sanctioned event, only the mat chairman or the Head Official for the event may order the video review. Even in the case where the referee and judge are in agreement of the results of an action or situation, video review **can** be ordered.

CHAPTER 11 - MEDICAL

Article 57 - Medical service

USAW Modification: *Policies and procedures for medical services at USAW sanctioned regional and national events is described in the official event flyer for the event. This article is to be used as a guideline only for USAW sanctioned events.*

As specified in the Regulations defining the international competitor's licence, each wrestler must undergo a medical examination in his own country three days before leaving for Championships, Cups and Games.

The organizer of the competition in question is obliged to provide a medical service responsible for conducting medical examinations prior to the weigh-in and give medical control during the bouts.

The medical service, which is required to operate throughout the competition, is under the authority of the FILA doctor in charge.

Before the competitors weigh in, the doctors shall examine the athletes and evaluate their state of health. If a competitor is considered to be in poor health or in a condition that is dangerous to himself or to his opponent, he shall be excluded from participating in the competition.

Throughout the competitions, and at any time, the medical service must be prepared to intervene in case of an accident and to decide whether a wrestler is fit to continue the contest.

Doctors from the participating teams are fully authorized to treat their injured wrestlers, but only the coach or a team officer may be present while treatment is being administered by the doctor.

In no case may FILA be held responsible for an injury, disability, or death of a wrestler.

Article 58 - Medical service involvement

USAW Modification: *Policies and procedures for medical service involvement at USAW sanctioned regional and national events is described in the official event flyer for the event. This article is to be used as a guideline only for USAW sanctioned events.*

The FILA doctor in charge has the right and duty to stop a bout at any time through the mat chairman, whenever he considers that either competitor is in danger.

He may also stop a bout immediately by declaring one of the wrestlers unfit to continue.

The wrestler must never leave the mat, except in the event of a serious injury requiring his immediate removal.

In case of a wrestler being injured, the referee must immediately ask the doctor to intervene and must impose a sanction if the injury is not visible or bleeding.

If a wrestler has a visible injury or is bleeding, the doctor will have the time necessary to treat the injury and will decide if the wrestler can carry on the match or not. There is no time limit.

In the case of any medical dispute, the doctor for the team of the wrestler in question has the right to intervene in any treatment required, or to give his advice on an intervention or decision made by the medical service. Only the FILA Medical Commission delegate may propose to the officials that the bout be stopped.

In competitions where there is no official doctor, the referee can suspend the bout for a maximum of two minutes in a match. The officials decide if the wrestlers are acting intentionally or not, and must apply the procedure mentioned in the above paragraphs.

This stoppage can be allowed on one or more times and is valid for both wrestlers.

The time-keeper for the mat concerned will announce each 30-second interval.

The referee must invite the two wrestlers to return to the centre of the mat ten seconds before the two minutes are up.

In international competitions where the FILA Medical Commission is not represented, the decision to interrupt the bout will be taken by the FILA delegate or by the FILA nominated referee following consultation with the competition doctor and the injured wrestler's team doctor.

In all cases, the doctor making the decision to prohibit the wrestler from continuing the bout shall be of a nationality other than that of the wrestler in question, and the doctor must not be involved in the weight class concerned (see health regulations).

The wrestler who deliberately stops the bout without being injured or bleeding, automatically loses 1 point to his opponent.

All first aid injuries (requiring no hospitalization) occurring in FILA international competitions are at the organizer's costs. The injuries requiring hospitalization are covered by the FILA license, provided that the case has been announced to the insurance company (at the number appearing at the back of the card) the same day.

Article 59 - Doping

In applying the provisions of the FILA Constitution, and in order to combat the possibility of drug use, which is formally prohibited, FILA reserves the right to require that wrestlers undergo examinations or tests in all competitions it supervises.

This provision must be applied at Continental and World Championships, according to FILA Regulations, and at the Olympic and Continental Games, according to IOC Rules.

In no case competitors or officers may oppose this verification without incurring immediate elimination and the penalties imposed for doping.

The FILA Medical Commission will decide the time, the number or frequency of these examinations, which will be carried out by any means it deems useful.

Suitable samples will be taken by a doctor certified by FILA, in the presence of an officer for the wrestler to be tested.

Where sampling is not carried out under the conditions set out above, the results obtained shall be considered void. (See doping regulations).

The setting up and financial implications of the anti-doping controls are paid for by the host country and the National Federations.

The FILA, being subject to the convention fighting drug use signed with the IOC and applied by the World Anti-Doping Agency (WADA), all its Regulations, procedures and sanctions are applicable by the FILA.

The appeal body in the event of a doping sanction made by the FILA Bureau against a wrestler is the Court of Arbitration for Sport (CAS) in Lausanne (Switzerland).

CHAPTER 12 - APPLICATION OF WRESTLING RULES

These Rules supersede all former editions.

The FILA Executive Bureau is the sole decision-making authority concerning any modifications to the above provisions that are deemed desirable with a view to improving the technical Rules of wrestling.

These Rules have been drawn up bearing in mind all the circulars and information distributed by the FILA.

They contain all the suggestions put forward by the auxiliary bodies and the Bureau which were accepted by the FILA Congress.

These Rules are the only valid document of their type until the following Congress which will be asked to rule on all the possible modifications or interpretations decided by the Executive Bureau.

In the event of a trial, only the French text is valid.

The National Federations must translate this document into their official language.

Every referee at a competition must have copy of these Rules in his language and in one of the FILA's official languages (French or English).

APPENDIX 1 - BASIC VOCABULARY

Every member of the officiating team must be perfectly familiar with and apply the vocabulary set out below. This vocabulary constitutes the official means of communication between members.

- 1) **SALUT** The wrestlers must greet each other.
- 2) **START** The invitation to the wrestlers standing at opposite corners of the mat to step to the centre to be examined and shake hands. After this, they will return to their respective corners and await the referee's whistle calling on them to begin wrestling.
- 3) **CONTACT** The referee calls upon the wrestler to place both his hands on the back of his opponent, who is underneath on the ground. Wrestlers in the standing position must assume 'body-to-body' contact.
- 4) **OPEN** The wrestler must alter his position and adopt more open wrestling tactics.
- 5) **DAWAI** The referee encourages the wrestlers to wrestle more actively.
- 6) **ATTENTION** The referee warns the passive wrestler before requesting a caution for refusal to assume the correct "par terre" position.
- 7) **ACTION** The wrestler must execute the hold that he has initiated.
- 8) **HEAD UP** The wrestler must raise his head. This order is given by the referee in the case of repeated attacks by a wrestler who thrusts his head forward.
- 9) **LEG** The wrestler has committed a leg error (Greco-Roman).
- 10) **POSITION** Initial position of the wrestlers on the ground (or in ordered contact in Greco-Roman wrestling), before the referee blows his whistle
- 11) **A TERRE** The bout is resumed in the "par terre" position.
- 12) **PLACE** By striking the mat with his hand and at the same time pronouncing the word 'place' the referee reminds the wrestlers not to flee the mat.
- 13) **DANGER** The danger position.
- 14) **FAULT** An illegal hold or violation of the technical Rules
- 15) **STOP** This word means the stopping of the bout.
- 16) **ZONE** This word must be spoken in a loud voice if the wrestlers enter the red zone.
- 17) **CONTINUE** The bout must be resumed upon this order by the referee. The referee also uses this word to have the wrestling continued if the wrestlers stop due to confusion and look at him as if they are asking for an explanation.
- 18) **TIME OUT** When one of the wrestlers stops wrestling, intentionally or because of injury or any other reason, the referee will use this expression to ask the timekeeper to stop his stopwatch.
- 19) **CENTRE** The wrestlers must return to the centre of the mat and continue the bout there.
- 20) **UP** The bout must be resumed in the standing position.
- 21) **INTERVENTION** The judge, referee or mat chairman call for intervention.
- 22) **OUT** A hold applied outside the mat.

- 23) **OK** The hold is valid (legal, correct). If the judge and mat chairman are sitting in a position that does not allow them to follow closely what is taking place on the opposite side, the referee must raise his arm to indicate whether the hold at the edge of the mat was executed within the boundaries of the mat or outside.
- 24) **NON** This word is used to indicate that an action is not valid and is consequently void.
- 25) **TOUCHE** The word used to indicate that the wrestler is beaten by a 'fall.' For a fall, the referee himself says 'tombé', strikes the mat with his hand, and blows his whistle to indicate the end of the bout.
- 26) **DECLARE BATTU** The decision made subsequent to a defeat by decision of the officiating team.
- 27) **DEFEAT** The opponent is beaten.
- 28) **DISQUALIFICATION** The disqualification is announced for unsportsmanlike conduct or brutality.
- 29) **FIN** The end of the bout.
- 30) **CHRONOMETRE** The timekeeper must stop or start the stopwatch on this order from the referee.
- 31) **GONG** The sound of the gong marks the beginning and end of a bout.
- 32) **REFEREE** The official conducting the bout on the mat.
- 34) **JUDGE** The official who assists the referee and awards the points to the wrestlers during the bout. He is also required to note all the actions executed during the bout on his score sheet.
- 35) **MAT CHAIRMAN** The mat chairman, who is the official responsible for a mat. He is obliged to break a tie vote between the referee and judge in case of a dispute.
- 36) **CONSULTATION** The mat chairman consults with the referee and judge before announcing a disqualification or decision on any matter on which there has been disagreement.
- 37) **CAUTION** The penalty issued by the referee to a wrestler for violation of the Rules.
- 38) **CLINIC** The referees' course.
- 39) **PROTEST** The protest filed as a result of a decision, whatever it may be.
- 40) **DOCTOR** The official doctor for the bout.
- 41) **VICTORY** The referee declares the winner.
- 42) **NO JUMP** Referee's comment to the wrestler par terre who jumps forward in order to prevent his opponent being able to initiate a hold.
- 43) **ORDERED HOLD** Provision laid down in article 49.
- 44) **SCORESHEET** Sheet on which the match results are entered.
- 45) **ROUNDSHEET** Competition sheet on which the brackets appear.

APPENDIX 2 – BEACH WRESTLING

REGULATIONS FOR MEN AND WOMEN

Age categories

- 10 to 15 years cadets
- 16 to 20 years juniors
- 21 years and more seniors

Weight categories

The person in charge divides the participants into 2 categories:

- One light category
- One heavy category

There is no weigh-in, the distribution in the categories is carried out according to the corpulence of the participants and in order to reach the quickest possible ideal divisible number .

Kinds of competition

Tournament or championship open to all without any affiliation nor license

Tournament or championship reserved for those affiliated to a National Federation

Competition dress

- Trunks for men without any other accessory
- Swimsuit in one piece or two pieces for women without any other accessory

Competition surface

On sand, inside a circle of 6 m diameter

Duration of the matches

One period of maximum three (3) minutes

Competition system

The competition takes place with direct elimination. The losers of the 1/2 finals are both ranked in the 3rd place

Identification of the men and women wrestlers

After having been distributed by categories, each wrestler receives an ankle band numbered from 1 to ...(different for each category) to be put around the ankle. After each match the loser hands the band to the referee.

Officiating

The person in charge acts as referee and his decisions cannot be questioned.

Kind of victories

“Beach Wrestling” is held only in the standing position. The victory can be obtained in the following manner:

- By fall when a wrestler touches both shoulders on the ground
- By throw when a wrestler has succeeded in having his opponent touch twice during the match a part of his body on the ground. In the action the attacking wrestler can put one or both knees on the ground.
- By leaving the competition area if a wrestler has succeeded in pushing twice one foot of his opponent out of the competition area.
- By adding to a throw a leaving of the competition area.
- By decision of the person in charge when at the end of 3 minutes no action was executed by one wrestler compared with the activity of the other wrestler.

Prohibitions

- Kick or punch
- Attack the face or the hair
- Cover the body with an oily and slippery substance
- Holds that can lead to a dislocation
- Stopping the match for any reasons is forbidden

Classification

One 1st, one 2nd and two 3rd places are declared for each light and heavy category .

The two first of each category must wrestle to determine the winner of the absolute category of the tournament.

- 1st of the light category against the 1st of the heavy category
- 2nd of the light category against the 2nd of the heavy category

USA Modifications

FILA encourages and conducts age group competitions, and has only a few special rules for youth wrestling. USA Wrestling, on the advice of its Sports Committees, JOWC and its Sport Science volunteer staff, has adopted modifications of the rules for specific age groups or levels of competition in this country.

For domestic sanctioned regional and national competitions, USA Wrestling applies modifications to age limits, weight classes and allowances, weigh-in procedures and rules, time and duration of weigh-ins, drawing of lots, pairing and bracketing procedures, separation of contestants, and on-the-mat competitive rules.

International competition, and USA Team Trials leading to World and Olympic competition, are conducted without modifications of the FILA rules, except those procedures adopted for ranking, pairing the contestants, protests, blood rules and weigh-ins.

Blood Rule

The following regulations apply to all levels of competition conducted and sanctioned by USA Wrestling:

1. Athletes known to be infected with the HIV/HBV virus cannot compete in any USA Wrestling sanctioned event.
2. Health care attendants known to be infected with AIDS cannot administer to bleeding athletes.
3. Anytime an athlete bleeds during a bout, the action shall be stopped immediately and first aid administered.
4. A bleeding athlete cannot compete unless the bleeding and spread of blood is effectively stopped. If the spread of blood to others cannot be effectively prevented to the satisfaction of the Chief Medical Officer and officials, then the athlete cannot compete further.
5. Time outs to stop bleeding or the spread of blood shall not be included in injury time. The cumulative time out to stop bleeding and the spread of blood shall not exceed five minutes.
6. Blood must be cleaned from the mats, uniforms and bodies with a bleach solution, and all used towels and other cleanup materials must be properly and immediately disposed of in a separate container for contaminated material.
7. Competition cannot resume until all blood has been removed and the cleaning solution residue has dried.

Pairing Procedures

The FILA format has been deemed unsuitable, at this time, for such events as the USA Wrestling Junior Nationals and Cadet Nationals, with their huge entry totals. USA Wrestling will conduct national and regional events in the Junior, FILA Cadets, Cadet and Kids Divisions under the vertical pairing format or similar formats.

National championships in the University, FILA Junior World and Veterans Divisions will be conducted under the seeded double elimination format, and in the Senior Division under a modified seeded double elimination format.

For many USA Wrestling sanctioned events in 2012, the use of computer assisted bracketing will be implemented. Even though much of the pairing procedures and policies apply in general, there may be situations that necessitate a modification or revision to the policies and procedures as they come to light.

Weigh-ins and Drawing of Lots -General-

At all regional and national championships, a weighmaster, his/her assistant, a drawmaster and his/her assistant, and additional personnel as needed are assigned. Assignments are made either by the USWOA or the chief official. The weighmaster, drawmaster and assigned medical officer must check the weigh-in area at least one hour before the start of weigh-ins to approve or adjust the physical layout and to assure an orderly process for the medical check, weighing in and drawing of lots.

During registration or weigh-in depending on the age group, the contestant will draw a number to determine his/her place on the brackets. Enough draw numbers must be provided so that no two contestants can draw the same number. The contestant's draw number is entered on the designated area of his/her weigh-in card. The drawmaster will supervise this process, and be available for questions.

Athletes must be prepared and must submit to a skin disease screening prior to weigh-in. A doctor's note on said doctor's official letterhead may be required stating that a current skin condition is not contagious. The chief medical officer for the event has full authority without appeal in determining the eligibility of an athlete to compete.

After a contestant has cleared medical check, the contestant has his/her weight confirmed at the scales and verified on his/her weigh-in card. If the athlete does not make the desired weight the card is **not** to be returned to the athlete. The athlete must then immediately verify his/her weight at a challenge scale. There shall be two attempts only to make the desired weight class (initial and one challenge). All athletes must be present at the beginning of weigh-ins. Weigh-ins shall end upon the last wrestler in line weighing in, or as stipulated for the event. These procedures do not apply to Senior level competitions or those competitions which qualify athletes for World Level events. The FILA rules pertaining to weigh-ins shall apply with USA Wrestling modifications.

The drawing of lots is integrated into the registration process as standard procedure and the roles of weighmaster and drawmaster require officials with a keen sense of fairness and responsibility. A newly developed guide to weigh-ins and the drawing of lots will be adhered to at national events and should be used at all other events when feasible. This guide may be obtained by contacting the USAW National Headquarters.

Where computer assisted bracketing is utilized, drawing of lots will be performed by random selection by computer.

THE TOURNAMENT COMMITTEE

All USA Wrestling regional and national events shall be governed by a tournament committee established by the event coordinator. The committee shall number at least five and no more than nine members, who shall be residents of different geographical areas, if possible.

One member shall be designated chairperson. When possible, a majority of the members shall be USWOA officials of Category M1 national rating.

The chairperson of the tournament committee shall appoint three or more members of the committee, and he may include himself, to rule on any formal protest. He shall select members of the committee from geographical areas different from those of the contestants and officials involved in the protest. No member of the protest committee shall be from the same local area of the parties involved.

When possible, the protest committee should include the chief mat official and the chief pairing master.

Special Tournament and Protest Committee procedures are in place for the Senior, University, FILA Junior Division Nationals and World Team Trials.

Senior (Olympic) Division

For contestants 20 or older (born in 1992 or before). Wrestlers 18-19 may enter with a medical certificate. For senior women only, wrestlers 17-19 may enter with a medical certificate.

Competition shall be conducted under a modified double elimination line bracketing. Wrestlers may be seeded and separated on the basis of previous performance, and further separated by club affiliation, in accord with USA Wrestling procedures listed herein.

Time and duration of weigh-ins may be modified to accommodate the needs of the athletes. The national championships are closed to foreign athletes.

Seeding and Separation

These rules, policies and procedures are subject to change as determined by the appropriate USAW Committee(s) and Board of Directors.

At the National Championships in each style, members of Team USA and other wrestlers worthy of national ranking are selected by the appropriate Sport Committee, or its designated subcommittee, to be seeded and separated from each other. The committee meets immediately after the close of the weigh-ins and drawing of lots.

In each weight class, the weigh-in cards of the wrestlers selected by the committee for seeding are segregated from the remainder of the weight class. The committee designates No. 1 and No. 4 wrestlers in the weight class, to be drawn in the first and second quarters of the bracket, respectively, and Nos. 3 and 2 to be drawn in the third and fourth quarters, respectively. See chart page 95.

Within the limits listed below, the committee then may assign additional wrestlers, divided equally, to the half-brackets, those rated 5-8-9-12-13-16 in the upper half, 6-7-10-11-14-15 in the lower half.

The limitations on the number of seeded entries are as follows:

- If there are 12 or fewer entries in the weight class, up to four wrestlers may be seeded and separated.
- If there are 13 to 32 entries in the weight class, up to eight wrestlers may be seeded and separated.
- If there are 33 to 64 entries in the weight class, up to 12 wrestlers may be seeded and separated.
- If there are more than 64 entries in the weight class, up to 16 wrestlers may be seeded and separated.

- Seeding must be based on documented achievement. When information is in question, it is not advisable to seed those contestants. Seeding may stop at any point up to the limits.
- When a contestant has been nominated for a seed because of documented achievement, his/her name may not then be withdrawn because of a potential adverse pairing.

Team Scoring (for both Men and Women's divisions)

Division I — Teams with 7 or more entries.

Division II — Teams with 7 or fewer entries.

A team must be a USA Wrestling chartered club. Club members must be a member of the club at the time of the championships.

A complete roster of all athlete members must be on file at the national office at least three business days before registration for the event. The club's list of entries for the event must be submitted at registration.

A Division I team may enter as many wrestlers as it wishes, but may score only its top 20 place winners. It need not designate its scorers in advance.

Points — 8-7-6-5, etc., when awards are given for eight places, or 6-5-4, etc., for six places, etc.

University Division

These rules, policies and procedures are subject to change as determined by the appropriate USAW Committee(s) and Board of Directors.

Each participant must be age 18-24 and his/her class must have graduated from high school. Ages are determined by year of birth - (1988 through 1994).

For all age groups University Division and below, a wrestler is not withdrawn from competition if he/she forfeits (unless it's his/her second loss). Instead, the match will be recorded as a loss and he/she will receive zero classification points, with the winner receiving five points.

These events are closed to foreign teams and athletes.

The National Men's Championships in both styles will be conducted under double elimination line bracketing. **Women's Championships shall be conducted under the two pool vertical system.**

Wrestlers shall be entered into their respective weight divisions by blind draw, which may include computerized blind draw, and there shall be a wrestle-off for True Second, in the case where the second and third place wrestlers have not met. This TRUE second place match shall not change the placing in the tournament and shall only be used for consideration of post event rankings, team selection, qualification for subsequent trials, etc.

The bouts for True Second shall take place 15 to 30 minutes after the final bout per style.

Time and duration of weigh-ins may be modified.

FILA Junior World Division

These rules, policies and procedures are subject to change as determined by the appropriate USAW Committee(s) and Board of Directors.

For contestants 18 to 20 (born in 1992 through 1994). A wrestler 17 (born 1995) may enter with a medical certificate.

For all age groups University Division and below, a wrestler is not withdrawn from competition if he/she forfeits (unless it's his/her second loss). Instead, the match will be recorded as a loss and he/she will receive zero classification points, with the winner receiving five points.

These events are open to foreign teams and athletes who meet the qualifications listed above.

The National Men's Championships in both styles will be conducted under double elimination line bracketing. **Women's Championships shall be conducted under the two pool vertical system.**

Wrestlers shall be entered into their respective weight divisions by blind draw, which may include computerized blind draw, and there shall be a wrestle-off for True Second, in the case where the second and third place wrestlers have not met. This TRUE second place match shall not change the placing in the tournament and shall only be used for consideration of post event rankings, team selection, qualification for subsequent trials, etc.

The bouts for True Second shall take place 15 to 30 minutes after the final bout per style.

Time and duration of weigh-ins may be modified.

Junior, Cadet, FILA Cadet and Kids Divisions

These rules, policies and procedures are subject to change as determined by the appropriate USAW Committee(s) and Board of Directors.

General Policies & Regulations

The following regulations apply equally to the four divisions:

USE OF FLUIDS

Athletes will be allowed to drink water, common sports drinks, juices or carbonated beverages during appropriate times of a bout, including the break between periods.

USE OF INHALANTS

Athletes will be allowed to use prescription inhalants (issued by a physician) during a bout for their well being.

FOLKSTYLE COMPETITION

For folkstyle competitions, the National Federation of State High School Associations match scoring wrestling rules are suggested guidelines, with the addition of the USAW Kids illegal hold modifications, for Kids Division events, and no one period to exceed two minutes. Weight classes may be modified. **In folkstyle wrestling, the three quarter nelson with a leg hook is legal in USAW Folkstyle events.**

At the Folkstyle Nationals, a true-second place match shall be wrestled in cases where the second and third place finishers have not met.

MOVING UP WEIGHT CLASSES

A wrestler may move up one weight class from the weight in which he/she is qualified to compete in at the time of weigh-in, except for heavy weight category, for which the contestant must weigh over the weight class just prior to the heavy weight class. For the Junior, Cadet, Schoolboy/girl, etc. Dual Championships, athletes may wrestle one weight class above the one in which they have qualified for at the official weigh-ins. In all cases, the actual weigh-in of athletes shall establish the weight class of each wrestler competing in the National Duals and shall supercede any listed weight class previously submitted. Other rules may apply.

MAT OFFICIALS

For all age group National Championships, excluding the Senior division, and when feasible, no official shall officiate a bout when it involves athletes from his/her state.

AGE GROUP ELIGIBILITY

An athlete shall only compete for two years in the age group designated by birth year for Bantam, Intermediate, Novice, Schoolboy/girl, and Cadet divisions. Violators shall be penalized one year eligibility.

WEIGH-INS

(These rules do not apply to the Senior Division)

For the Junior Division Regional Championships, athletes must weigh-in a maximum of three hours and minimum of two hours prior to the start of competition. For Junior Division National Championships, athletes must weigh-in a maximum of four hours prior to the start of competition.

For all age groups, athletes shall have two consecutive opportunities during the scheduled weigh-in to make the weight indicated at time of registration. Athletes shall not be allowed to leave the designated weigh-in area during the weigh-in process. The two consecutive opportunities to make the weight class are: initial weigh-in and one immediate challenge.

Only for the Cadet Division & Junior Division National Competition shall athletes be required to weigh-in on subsequent days (one) following initial weigh-in.

For the initial weigh-ins, an athlete may move up one weight class if he/she fails to make the weight indicated during the registration process, with the exception of the Cadet and Junior National Championships where there are limits per weight per state (4). For Junior Division Regional Championships and the Cadet Division and Junior Division Nationals, the athlete moving up in weight class shall be placed in the next weight-class above on the first available position as determined by the Chief Pairing Official assigned to the event.

Athletes paired against an opponent who failed to make weight may in some cases earn five (5) positive points and advance, if no other athlete moves up from a lower weight classes failing to make weight. The Chief Pairings Officials has final authority on all such cases.

Athletes must weigh-in in their competition singlet.

For the Cadet and Junior National Championships, athletes maybe moved in weight class if authorized in writing by the respective State Chairperson or designee.

Other rules related to weigh-ins where the event qualifies for an international event shall apply.

FORFEIT

For all age groups University Division and below, a wrestler is not withdrawn from competition if he/she forfeits (unless it's his/her second loss). Instead, the match will be recorded as a loss and he/she will receive zero classification points, with the winner receiving five points.

MOUTH GUARDS

USA Wrestling strongly encourages, but does not mandate, the use of mouth guards in all developmental age group competitions. This also applies to athletes with braces.

Junior Division

These rules, policies and procedures are subject to change as determined by the appropriate USAW Committee(s) and Board of Directors.

For all domestic competition except international team trials, a Junior wrestler must be a student-athlete currently attending high school (grade 9, 10, 11 or 12), or participating in a program considered by the State's Department of Education to be fulfilling the athlete's requirements for graduation from an accredited high school program, or if a summer event, attending high school, or participated in a program considered by the State's Department of Education to be fulfilling the athlete's requirements for graduation from an accredited high school program, the Spring semester just prior to the summer event. In addition, the athlete has only four (4) consecutive years to compete in the Junior Division once his class begins the ninth grade, and he/she must have been born on or after September 1, 1992.

There are 15 weight classes (Men's):

- | | |
|------------------|-------------------|
| 1. up to 100 lbs | 9. up to 152 lbs |
| 2. up to 106 lbs | 10. up to 160 lbs |
| 3. up to 113 lbs | 11. up to 170 lbs |
| 4. up to 120 lbs | 12. up to 182 lbs |
| 5. up to 126 lbs | 14. up to 195 lbs |
| 6. up to 132 lbs | 12. up to 220 lbs |
| 7. up to 138 lbs | 15. up to 285 lbs |
| 8. up to 145 lbs | |

There are 12 weight classes (Women's):

- | | |
|------------------|-------------------|
| 1. up to 97 lbs | 7. up to 130 lbs |
| 2. up to 105 lbs | 8. up to 139 lbs |
| 3. up to 112 lbs | 9. up to 148 lbs |
| 4. up to 117 lbs | 10. up to 159 lbs |
| 5. up to 121 lbs | 11. up to 172 lbs |
| 6. up to 125 lbs | 12. up to 198 lbs |

International ages and weights are listed on page 14.

At the Junior National Championships, competition shall be conducted under the two pool vertical pairing format, with returning place winners and world medalists separated from each other. Wrestlers from the same state also are separated.

Separation shall occur using three levels. Wrestlers shall be given priority based on the level at which they qualify to be separated. After determining the wrestlers that qualify to be separated and their level the procedures described below shall be followed.

Separation Levels & Procedures for Junior National Championships:

Level One: Previous Junior Division and above National Champion in style.

Level Two: Previous Cadet and FILA Cadet National Champion in style, previous Junior National Division and above 2nd-8th place in style.

Level Three: Previous year Cadet and FILA Cadet Division National 2nd-8th place winners in style, previous Junior Division and above National Champion out of style (includes folkstyle).

Level Four: Wrestlers from the same state shall be separated.

The USA Wrestling Developmental Staff Coaches, or their designees, shall review weight classes prior to bracketing to ensure proper identification of previous year National Champions and All-Americans.

First, check the states of each Level as it is separated. If Level One has two from the same state, place one in Pool A & one in Pool B immediately, low draw number to Pool A. Check the states of each Level and separate them into pools, first.

Level One wrestlers are separated first. The Level One wrestler with the lowest draw number is placed in Group A and cards of the remaining Level One Wrestlers are dealt alternately in order of their draw numbers, starting with Group B. If there is an odd number of Level One wrestlers, the odd card (highest draw number) is placed aside.

Level Two wrestlers are separated. Check States. The Level Two wrestler with the lowest draw number is dealt to Group A and the other cards are dealt alternately, as above. If there is an odd number of Level Two wrestlers, the odd card (highest draw number) is placed with the single Level One card.

Level Three wrestlers are separated. Check States. The Level Three wrestler with the lowest draw number is placed in Group A and the other cards are dealt alternately, as above. If there is an odd number of Level Three wrestler, the odd card is placed with the single Level One and Level Two cards, if there are such cards.

If after separation of Level One, Level Two, and Level Three cards, there are **two cards** left (from any combination of the three levels), place them in

draw number order, lowest to highest. The lowest draw number of the two is assigned to the A Pool and the highest draw number to the B Pool.

If after separation of Level One, Level Two, and Level Three cards, there is **one card** left, place it in the unassigned deck. **This will prevent the extra Level wrestler from always being in the A Pool.

Level Four: Wrestlers from the same state are separated. When sorting cards by states at a large tournament, the stacks of state cards first should be arranged in alphabetical order of states, to be sure there are not two stacks from one state.

If the state team leader has designated a ranking within the state, his/her No. 1 and No. 2 wrestlers are compared and the wrestler with the lower draw number is placed in Group A. If there is a wrestler in either pool from that same state classified as a Level ONE, Level TWO, or Level THREE, then the No. 1 wrestler from that state should be placed in the opposite pool. The No. 2 wrestler will be assigned the pool opposite No. 1 from his/her state.

If two wrestlers are designated as No. 1, separate them; if two wrestlers are designated as No. 2, separate those two.

Wrestlers designated No. 3 and No. 4 within their state then are compared and the wrestler with the lower draw number is placed in Group A. If there are only three entries from one state, the third card is returned to the unassigned deck.

If no ranking within the state is designated on the card, the wrestler with the lowest draw number is placed in Pool A. If there are 3 entries, low draw number in Pool A, high draw number in Pool B, the third card returns to the unassigned deck. If there is an equal number from that state, deal to alternate pools. If there is an odd number (5 or 7) the last card, highest draw number, is placed in the unassigned deck, except for three entries as mentioned above.

After this separation has been completed, count the number in each pool. Place the unassigned deck in draw number order, lowest to highest. Both pools should have an equal number of wrestlers; therefore, the alternating deal starts in Group A. If there is not an equal number in each pool because of state adjustments, add one or more cards from the unassigned deck to make the pools equal before distributing the other unassigned cards.

Adjustments for Level One, Level Two, and Level Three: Adjustments shall be made so that neither Pool A nor Pool B will contain an unequal representation of Level wrestlers from any state, other than by one. In case a wrestler must be moved, the second wrestler placed shall be moved to the opposite pool, exchanging places with the **same level** wrestler from another state whose draw number is closest to his/her.

Two Level One wrestlers should be half a pool apart, or if three Level One wrestlers in a pool, a third of a pool, etc. All Level One, Level Two, and Level Three, wrestlers should be separated by an equal number of contestants (Divide the total number of entries in the pool by the number of Level One, Level Two, and Level Three wrestlers in the pool - 48 divided by 4 = 12) If there are two Level Ones, they should be separated by 24 and the two Level Two in between by equal distance of 12.

Adjustments for Level Four: Two or three wrestlers from the same state should be separated by at least a third of the pool; If not they should be moved equidistant from each other. If the number of contestants between two or three wrestlers from the same state is less than a third, the lowest draw number will be moved, unless it would be necessary to move him/her to the end of the weight class (do not move a wrestler over the top). In that case, the higher draw number will be moved one-half the distance away for 2 wrestlers, or one-third the distance away for 3 wrestlers. His/her card is inserted at that point, with other cards remaining in order.

In the search for such conflicts, pairings are reviewed once from the top down, and each conflict resolved in turn. After the conflicts have been resolved, the wrestlers are paired for the first round.

A wrestler shall lose his/her state ranking criteria if he/she misses weight and moves up to an available slot at the next weight class.

Separation Procedures for Junior Regional Events:

At Junior Regional championships, competition may be conducted under the two pool vertical pairing format or double elimination line bracketing; there is no seeding or separation based on past performance, but there is separation by states. Separation of athletes from the same town/cities is strongly encouraged using the process below.

States shall be separated in pools by the following rules: First, in each weight class, separate all contestant's cards from the same state; place them in ascending order according to each wrestler's draw number which has been drawn by the contestant at registration.

To separate two contestants, place the lower draw number of the two in Group A, the higher in Group B. For three contestants, place the lowest draw number in A, the highest in B, the other back in the unassigned deck. For four, deal alternately by number to A and B; for five, seven, nine, eleven contestants, deal alternately by number to A and B, but place the last odd number in the unassigned deck. When all state separations have been made, sort the remaining cards in ascending numerical order and deal them alternately to Groups A and B. Then sort each pool in ascending numerical order. Separate each state within each pool. If the number of contestants between two or three wrestlers from the same state is less than a third, the lowest draw number will be moved, unless it would be necessary to move him/her to the end of the weight class (do not move a wrestler over the top.) In that case, the higher draw number will be moved one-half the distance away for 2 wrestlers, one-third the distance away for 3 wrestlers, one-fourth the distance away for four wrestlers, etc. His/her card is inserted at that point, with other cards remaining in order. Sometimes, there are too many entries from the same state for this formula. In that case, you should separate as much as possible so that they do not meet for at least two rounds.

In the search for such conflicts, pairings are reviewed once from the top down, and each conflict resolved in turn. After the conflicts have been resolved, the wrestlers are paired for the first round.

There is no team scoring in Junior competition.

Time and duration of weigh-ins may be modified.

USAW Cadet Division

These rules, policies and procedures are subject to change as determined by the appropriate USAW Committee(s) and Board of Directors.

For contestants age 15-16 (born in 1996 or 1997).

For domestic competition, there are 17 weight classes:

1.	up to	88	lbs	Wm	84	10.	up to	145	lbs	Wm	154
2.	up to	94	lbs	Wm	88	11.	up to	152	lbs	Wm	170
3.	up to	100	lbs	Wm	95	12.	up to	160	lbs	Wm	198
4.	up to	106	lbs	Wm	101	13.	up to	170	lbs		
5.	up to	113	lbs	Wm	108	14.	up to	182	lbs		
6.	up to	120	lbs	Wm	115	15.	up to	195	lbs		
7.	up to	126	lbs	Wm	124	16.	up to	220	lbs		
8.	up to	132	lbs	Wm	132	17.	up to	285	lbs		
9.	up to	138	lbs	Wm	143						

There is no team scoring in Cadet competition.

Time and duration of weigh-ins may be modified. At the regional championships, national and regional policies on qualification, changing weight classes, etc., prevail.

These rules, policies and procedures are subject to change as determined by the appropriate USAW Committee(s) and Board of Directors. It should be noted that the rules prohibit the full nelson and the three-quarter nelson with a leg hook.

Separation Levels & Procedures for National Cadet Championships:

At the Cadet National Championships, competition shall be conducted under the vertical pairing format. Separation of wrestlers within the weight classes shall follow the same procedures as described for the Junior Division. The separation criteria, which differs from the Junior Division, is provided below. Wrestlers also are separated on the basis of state team affiliation, in accordance with USA Wrestling procedures listed for the Junior Division.

Level One: National Cadet Division and above National Champion in the style.

Level Two: Previous Cadet National and above 2nd-8th place finisher in the style.

Level Three: Previous Cadet National and above out of style champion (includes folkstyle), top three finishers in style from last year Kids FS/GR National Championship

Level Four: Wrestlers from the same state shall be separated.

The USA Wrestling Developmental Staff Coaches, or their designees, shall review weight classes prior to bracketing to ensure proper identification of previous year National Champions and All-Americans.

Separation Procedures for Cadet Regional Events:

At CADET TOURNAMENTS that are part of a Kids/Cadet Championship, competition for cadets may be either by the pool system, two groups for each weight class of six or more contestants, or standard round-robin, each weight class a single group, or by double elimination line bracketing. There is no seeding or separation based on past performance, but there is separation by states. Separation of athletes from the same town/cities is strongly encouraged using the process below.

For separation of states into Pools, follow the directions under Separation at Junior Regional Tournaments. If the standard round-robin is used, states should be separated within the single group as much as possible. First, take a single weight class (Cadet, 125 lbs.) and place all contestant's cards in ascending order according to each wrestler's draw number which has been drawn by the contestant at registration. Lay them in numerical order on a table. If the number of contestants between two or three wrestlers from the same state is less than a third, the lowest draw number will be moved, unless it would be necessary to move him/her to the end of the weight class (Do not move a wrestler over the top.) In that case, the higher draw number will be moved one-half the distance away for 2 wrestlers, or one-third the distance away for 3 wrestlers. His/her card is inserted at that point, with other cards remaining in order. If there are four wrestlers from the same state, they should be one-fourth apart, five wrestlers should be one-fifth apart, etc.

In the search for such conflicts, pairings are reviewed once from the top down, and each conflict resolved in turn. After the conflicts have been resolved, the wrestlers are paired for the first round.

FILA Cadet Division

These rules, policies and procedures are subject to change as determined by the appropriate USAW Committee(s) and Board of Directors.

For contestants age 15-17 (born 1995-1997).

For men's competition, there are 10 weight classes (kg):

- | | |
|---------------------------|-------------------------------|
| 1. up to 92.5 lbs (39-42) | 8. up to 167.5 lbs (76) |
| 2. up to 101.25 lbs (46) | 9. up to 187.25 lbs (85) |
| 3. up to 110.0 lbs (50) | 10. up to 220.25 lbs (85-100) |
| 4. up to 119.0 lbs (54) | 11. up to 275.0 lbs (125) |
| 5. up to 127.75 lbs (58) | |
| 6. up to 138.75 lbs (63) | |
| 7. up to 152.0 lbs (69) | |

For Women's competition, there are 13 weight classes (kg):

- | | |
|----------------------------|-------------------------------------|
| 1. up to 83.75 lbs (36-38) | 8. up to 132.25 lbs (60) |
| 2. up to 88.0 lbs (40) | 9. up to 143.25 lbs (65) |
| 3. up to 94.75 lbs (43) | 10. up to 154.25 lbs (70) |
| 4. up to 101.25 lbs (46) | 11. up to 170.0 lbs (78) |
| 5. up to 108.0 lbs (49) | 12. up to 185.0 lbs (84) |
| 6. up to 114.5 lbs (52) | 13. up to 220.0 lbs (100) |
| 7. up to 123.25 lbs (56) | (11,12,13 are for USAW events only) |

Separation Levels & Procedures for National Cadet Championships:

At the FILA Cadet National Championships, competition shall be conducted under the two pool vertical bracketing system. Separation of wrestlers within the weight classes shall follow the same procedures as described for the Junior Division. The separation criteria, which differs from the Junior Division, is provided below. Wrestlers also are separated on the basis of state team affiliation, in accordance with USA Wrestling procedures listed for the Junior Division.

- Level One:** National Cadet Division and above National Champion in the style.
- Level Two:** Previous Cadet National and above 2nd-8th place finisher in the style.
- Level Three:** Previous Cadet National and above 1st-3rd place finisher out of style (not including folkstyle),
- Level Four:** Wrestlers from the same state shall be separated.

Wrestlers shall be placed according to draw number within the bracket. Procedures for placement of wrestlers and byes as described under the Senior Division shall apply.

There is no team scoring.

Time and duration of weigh-ins may be modified. See weigh-in policies above. It should be noted that the rules prohibit the full nelson, and the three quarter nelson with a leg hook.

Kids Division

These rules, policies and procedures are subject to change as determined by the appropriate USAW Committee(s) and Board of Directors.

USA Wrestling championships are conducted for four Kids Division age groups: Bantam Division, Intermediate Division, Novice Division and Schoolboy/Schoolgirl Division. A wrestler's age for an entire season is determined by the birthday he/she celebrates during the calendar year. A participant whose 14th birthday falls on any day of 2012 is considered 14 years old.

USA Wrestling does not conduct regional competition for contestants younger than 9, but state and local programs are offered.

KIDS DIVISION RULES MODIFICATIONS

On the advice of its Sport Science Committee, USA Wrestling has adopted modifications of the international rules. The following modifications apply to competition in the 2012 season.

Age Categories

Schoolboy/girl	Wrestlers born in 1998 or 1999.
Novice	Wrestlers born in 2000 or 2001.
Intermediate	Wrestlers born in 2002 or 2003.
Bantam	Wrestlers born in 2004 or 2005.

Weight Classes

Schoolboy/girl	70 pounds, 77, 84, 91, 98, 105, 112, 120, 128, 136, 144, 152, 160, 175, 190, 210, 265 (17 classes).
Novice	60 pounds, 65, 70, 75, 80, 85, 90, 95, 100, 105, 112, 120, 130, 140, and heavyweight (15 classes; heavyweights must weigh more than 140).
Intermediate	50 pounds, 55, 60, 65, 70, 75, 80, 87, 95, 103, 112, 120, heavyweight (13 classes; heavyweights must weigh more than 120).
Bantam	40 pounds, 45, 50, 55, 60, 65, 70, 75, heavyweight (9 classes; heavyweights must weigh more than 75).

All heavyweights must weigh in. If the difference between the lightest and heaviest contestants exceeds the allowable difference for that age group, the wrestlers must be divided into groups meeting these limitations:

Novice:	Maximum difference 25 pounds.
Intermediate:	Maximum difference 20 pounds
Bantam:	Maximum difference 15 pounds.

Event Directors should create weight classes for the heavy weights which allows for the maximum number of bouts per heavy weight class. For example: The first heavy weight class in Novice may be 152-167lbs. The first weight class does **not** have to be 165lb.

Duration of the Bout:

Freestyle and Greco-Roman

Schoolboy/ girl:	3 periods, 2 minutes each (2+2+2), with 30 seconds rest between periods.
Novice:	3 periods, 2 minutes each (2+2+2), 30 seconds rest.
Intermediate:	3 periods, 2 minutes each (2+2+2), 30 seconds rest.
Bantam:	3 periods, 2 minutes each (2+2+2), 30 seconds rest.

Folkstyle

Juniors:	Championship Bracket: 2:00 first period, 2:00 second period, 2:00 third period Consolation Bracket: 1:00, 2:00, 2:00
Cadet:	Championship Bracket: 2:00, 2:00, 2:00 Consolation Bracket: 1:00, 2:00, 2:00
Schoolboy/ girl:	Championship Bracket: 1:00, 1:30, 1:30 Consolation Bracket: 1:00, 1:00, 1:00
Novice:	Championship Bracket: 1:00, 1:30, 1:30 Consolation Bracket: 1:00, 1:00, 1:00

Intermediate:	Championship Bracket: 1:00, 1:00, 1:00 Consolation Bracket: 1:00, 1:00, 1:00
Bantam:	Championship Bracket: 1:00, 1:00, 1:00 Consolation Bracket: 1:00, 1:00, 1:00
Veterans:	Championship Bracket: 1:00, 1:30, 1:30 Consolation Bracket: 1:00, 1:00, 1:00

Scoring

1 Point: As defined in the international rules, except where noted under illegal holds.

2 Points: As defined in the international rules, except where noted under illegal holds.

3 Points: As defined in the international rules, except where noted under illegal holds.

5 Points: As defined in the international rules, except where noted under illegal holds.

There is no team scoring in Kids competition.

For **folkstyle competition**, the National Federation of State High School Associations match scoring wrestling rules will be enforced, with USAW modifications to the Kids' illegal hold rules. Other modifications may apply and are covered within these rules.

Weigh-ins

See above page 64.

Separation & Pairing

Separation Levels and Procedures for Kids National FS/GR Championships:

Level One: All-American (1-8 place) wrestlers who are returning in the same Age Division and the same style.

Level Two: Regional champions for each Age Division and each style.

Level Three: Wrestlers from the same state shall be separated.

Level One - All-Americans for each age division and each weight class are separated first. The All-American with the lowest draw number is placed in group A and cards of the remaining All-Americans are dealt alternately in order of their ascending draw numbers, starting with Group B. If there are two All-Americans from the same state, put them in opposite pools, low draw number in A Pool. If there is an odd number of All-Americans, the odd card (highest draw number) is placed aside.

Level Two - Regional champions are separated for each age division and each weight class. The regional champion with the lowest draw number is dealt to Group A and the other cards are dealt alternately as above. If there is an odd number of the regional champions, the odd card (highest draw number) is placed with the single All-American card.

If after separation of All-Americans and regional champions, there are two cards left (one All-American and one regional champion), place them in ascending draw number order. The low draw number is assigned to the A Pool, the high number is assigned to the B Pool.

If after separation of All-Americans and regional champions, there is one card left, place it in the unassigned deck.

Level Three - Wrestlers from the same state are separated. Place the contestants' cards from each state in ascending draw number order. Take the cards of each state separately and distribute into pools. If there is a wrestler in either pool who is an All-American or regional champion from that same state, start distributing alternately in the opposite pool first. If no ranking within the state is designated on the card, the wrestler with the lowest draw number is placed in pool A, high draw number to Pool B, the third card returned to the unassigned deck. If there is an equal number from that state, deal to alternate pools. If there is an odd number (5 or 7), the last card, highest draw number, is placed in the unassigned deck, except for three entries as mentioned above.

After this separation has been completed, count the number in each pool. Place the unassigned deck in draw number order, lowest to highest. Both pools should have an equal number of wrestlers; therefore, the alternating deal starts in Group A. If there is not an equal number in each pool because of state adjustments, add one or more cards from the unassigned deck to make the pools equal before distributing the other unassigned cards. If there is an extra card from the unassigned deck, it will be placed in the A Pool.

Take all cards assigned to the A pool and lay them out in draw number order.

Adjustments for Level One and Level Two: Check States. Adjustments shall be made so that neither Pool A nor Pool B will contain an unequal representation of Level wrestlers from any state, other than by one. In case a wrestler must be moved, the second wrestler placed shall be moved to the opposite pool, exchanging places with the **same level** wrestler from another state whose draw number is closest to his/her.

Two All-Americans should be a half pool apart, or if three All-Americans in a pool, a third of a pool apart, etc. In case a wrestler must be moved within a pool: If the Level wrestlers must be moved, the lowest draw number will be moved, unless it would be necessary to move him/her to the end of the weight class (do not move a wrestler over the top). In that case, the higher draw number will be moved one-half the distance away for 2 wrestlers, or one-third the distance away for 3 wrestlers. His/her card is inserted at that point, with other cards remaining in order. If there are four wrestlers at the same Level, they should be one-fourth apart, five wrestlers should be one-fifth apart, etc. If there are two Level Ones, they should be separated by one-half and Level Two's separated equidistant between them, if possible. The largest separation should be among the Level One's.

Adjustments for Level Three - Use the same instructions as listed above for state separation. In some cases separating the states is not possible because the pool is too small or there are too many from one state. If this is the situation, try to separate for two rounds, if possible. In the search for such conflicts, pairings are reviewed once from the top down, and each conflict resolved in turn. After the conflicts have been resolved, the wrestlers are paired for the first round. Repeat the above steps for separation for each pool in each age division and each weight class.

Regional Kids Championships:

Pairing formats may be selected from the following options:

- Double elimination line bracketing, pool system, two groups for each weight class of six or more contestants. The fifth place bout is not held unless it is appropriate to the number of awards.
- Standard round-robin, each weight class a single group.
- All Americans, from the prior year only, in all Kids Division age groups from the Kids Folkstyle National Championships shall be appropriately separated in the brackets in order that the possibility of them meeting occurs at the furthest possible round in the winners side bracket.

Illegal Holds

A prime responsibility of Kids wrestling officials is protection of the athletes against injury. The referee should guard against the development of illegal holds, and of legal but dangerous situations.

If the referee is unable to prevent the development of a dangerous hold by warning the wrestlers, he/she should blow the whistle and stop the bout. If the hold is illegal, the offender is penalized by a caution, and a technical point is awarded to the opponent. Other FILA rules pertaining to illegal holds apply.

If a wrestler is injured by an illegal hold and is unable to continue, the wrestler at fault is disqualified (classification points 5:0).

Illegal holds in the Kids Division include:

- A full, straight-back souplesse from a rear standing position, or the straight-back salto to the head.
- Slam ... lifting and returning an opponent to the mat with unnecessary force. May be committed by a contestant in either the top or bottom position, as well as during a takedown. A wrestler who lifts his/her opponent off the mat is responsible for his/her safe return. When a contestant is returned to the mat with undue force, so the upper half of his/her body contacts the mat first, it is a slam.
- Full nelson, even when applied from the side.
- Three-quarter nelson with a leg hook (**this move IS legal in USAW Kids Folkstyle Events**).
- Cross-chest cradle, West Point ride, Colorado or Iron Cross.
- Double arm bar with sit-out (double chicken wing).
- Neck wrench ... grasping the opponent's chin and twisting the neck. Grasping the chin is not in itself a violation, but pulling and twisting is illegal and potentially dangerous and threatens injury to the vertebrae. This situation can develop quickly from

attempting to neutralize a double-leg takedown, from countering a single-leg, reaching back from the down position, and in executing at least one form of fireman's carry. The neck must not be forced beyond normal limits.

Glossary

INTERNATIONAL TERMS

USA Wrestling	FILA
Announcer	Speaker
Caution	Warning or Caution
Warning	Passivity
Chief pairing master	Secretariat
Disqualification (cautions).....	Disqualification
Disqualification (misconduct).....	Brutality
Olympic, Open or Senior division	Senior division
Overtime	Extra Time
Paddles.....	Bats
Pools.....	Groups
Protest committee.....	Jury of appeal
Round-robin.....	Group finals
Scratch weight.....	No tolerance
Start sheet	Programme
Technical fall.....	Technical superiority
Order of Wrestling	Start list
Weight allowance	Tolerance

DEFINITIONS

Age: A wrestler's age is determined by the birthday he/she observes during the calendar year. For example, if he/she turns 15 on any day in 2012, he/she is considered 15 all year.

Amplitude: A throw lifting the opponent above the thrower's waist. Points vary for grand (high) amplitude and low amplitude.

Announcer: The person who calls wrestlers to the mat, conducts opening ceremonies and the presentation of awards, and makes any other public statements pertinent to the event.

Announcer's assistants: Persons who coordinate the flow of outgoing bout sheets to the announcer, keep track of the mats to which they go, and collect and check incoming bout sheets for the chief pairing master.

Back forcing: A term indicating that pairing "from the top down" has reached a momentary impasse, which can only be solved by backing up and trying another combination of wrestlers.

Blind draw: A drawing of lots where all positions are determined by chance, with no seeding or separation.

Bout: Competition between two wrestlers, a match.

Bout numbers: The method of showing in what order the bouts will be conducted.

Bout sheet: Form on which the judge keeps score for a bout.

Bout sheet tracking: A form that shows to which mat each bout has been assigned.

Bridge: When a wrestler supports himself on his/her head, elbows and feet to keep his/her shoulders from touching the mat.

Brutality: Unnecessary roughness, with clear intent to injure the opponent. Penalized by disqualification from the tournament.

Bye: The indication that a wrestler has no opponent in a given round.

Cadet: A wrestler in the 15-16 age group.

Call to the mat: The announcement for two wrestlers to report to a specific mat to compete.

Carry forward: When two wrestlers in the group finals already have met, the result of their previous bout is recorded as part of the group finals.

Category: The national or international ranking earned by a mat or pairing official. Also, the age group in which a wrestler competes.

Caution: The penalty against a wrestler for use of an illegal hold, fleeing a hold, fleeing the mat, or refusal to take a proper starting position. Three cautions result in disqualification.

Center: A 1-meter circle, the starting area in the center of the mat. Also, a command to the wrestlers to return to the center.

Central wrestling area: The middle of the mat, 7 meters across, where the action should take place.

Championship round: The finals, competition between place winners from the two groups to determine final placing in the tournament.

Chief clerk: The person who coordinates the preparation of bout sheets and wall charts.

Chief mat official: The person in charge of referees for an event.

Chief medical officer: The person in charge of the medical staff for an event. His/her decision as to whether an injured athlete may continue to wrestle is final, and not subject to appeal.

Chief pairing master: The person in charge of “head table” operations of the event.

Classification points: Positive points earned by the winner of a bout, and sometimes by the loser. These points help determine the ranking of the wrestlers at the close of competition.

Clerks: Persons who prepare bout sheets and wall charts.

Clinics: Instructional meetings for mat and pairing officials concerning rules and procedures, conducted by the respective chiefs or other senior officials. Also, explanations of rules for coaches and wrestlers. Technique clinics are demonstrations of methods of attack and defense so that wrestlers and coaches may improve their skills.

Continental championships: Competition limited to nations from a given area, e.g., Pan American, European, Asian, Oceanic.

Correct hold: A well-executed throw which neither scores a takedown, nor puts the opponent in danger. It can be awarded a point for “appreciation” of the throw.

Counter: An action which stops or blocks the offensive wrestler’s attack. A wrestler can score with a counter.

Crescents: Standard symbols used to mark round-robin participants (red crescents) and special bouts (black crescents).

Criteria: The list, in order, of tie-breakers.

Decision: Victory on points, by a margin of 1 to 5.

Default: A bout determined by injury to a contestant.

Disqualification: Elimination of one or both contestants from a bout with three cautions, or for misconduct. In the latter case, the wrestler(s) may be eliminated from the tournament.

Division: Age group or category in which a contestant competes.

DNWI: Standard notation that a wrestler did not attend a weigh in, or that he/she attended an event's second or third weigh-in, but was too heavy.

Domestic competition: Competition within the USA, not involving international teams.

Double bye: Term used when pairing a round requires byes for two contestants.

Draw number: Identification number for each contestant, determined by the drawing of lots, listed on the pairing chart at the left of the contestant's name.

Drawing of lots: Random selection of numbers by each contestant at registration or weigh-in depending on the age group.

Drawmaster: The person who conducts the drawing of lots.

Drug testing: Can be ordered for any contestant at any time, during any national or international event or trials, at the request of FILA, the U.S. Olympic Committee or USA Wrestling.

Dual meet: Competition between two teams, each team entering one wrestler in a previously determined number of weights.

Elimination: Removal of a wrestler from the competition, by a second defeat, an injury, forfeit, failure to weigh in, or misconduct.

Elimination rounds: The preliminary rounds of competition, to reduce the number of contestants to three in each group and to determine additional placings as needed.

Event coordinator: A representative of USA Wrestling assigned to supervise and coordinate the total operation of an event. This person has the authority to make decisions on any controversial subject. The domestic counterpart of the FILA representative.

Event director: Chairman of the local organizing committee, host administrator for the event.

Examinations: Tests given to mat or pairing officials leading to advancement in category.

Exposure: When the defensive wrestler's back is turned toward the mat without the head or an elbow touching (hand-to-hand). Not a danger position, so it can score only one point.

Face mask: A protective cushion worn because of injury. Prohibited in international events, but permitted by USA Wrestling when prescribed by a physician or by the chief medical officer of the event.

Fall: Victory by pinning an opponent's shoulders to the mat.

FILA: Fédération Internationale des Luttes Associées, the international governing body of wrestling.

FILA Cadet: A wrestler in the 16-17 age group. A wrestler 15 may enter this division with a medical certificate.

FILA Junior World (formerly Espoir): A wrestler in the 18-20 age group. A wrestler 17 may enter this division with a medical certificate.

FILA representative: The delegate assigned to supervise all aspects of an international event.

Fleeing a hold: Openly refusing contact to prevent the opponent from initiating or executing a hold, punishable by a caution, plus a penalty point and choice of position to the opponent.

Fleeing the mat: Leaving the wrestling area to avoid the opponent's attack, punishable by a caution, plus a penalty point and choice of position to

the opponent; two penalty points if fleeing occurs from a danger position.

Floor manager: The person responsible for arena equipment and personnel.

Flow chart: Document with which the chief pairing master monitors and controls the pace of the competition.

Forfeit: The result when a wrestler fails to appear for his/her bout.

Freestyle: One of the two international wrestling styles, where use of the legs is permitted.

Corriaran Trophy: An award formerly given to the wrestler who scores the most falls, in the least total time. Named for the man who originated the award.

Grand Amplitude hold: A high, sweeping throw during which the opponent is lifted completely off the mat.

Greco-Roman: One of the two international styles, where attacking the opponent's legs, and using one's own legs in an attack, is prohibited.

Group: One-half of the contestants in one weight class, a pool.

Group finals: Round-robin competition among the final three contestants in a group. Sometimes only two contestants are involved.

Gut wrench: Also called a body lock and bridge. A hold that uses the defensive man's torso to turn him to score points.

Handkerchief: Each wrestler must have one, and he/she should show it to the referee as he/she comes onto the mat.

Headgear: Ear protectors of various types. Authorized by USA Wrestling at the junior and younger levels. Optional for FILA Junior World and seniors, if there is no objection from the opponent.

Illegal hold: A hold or maneuver prohibited by the rules, punishable by a caution and one or two penalty points.

Injury time: An interruption of the bout because a wrestler is hurt. Each contestant is allowed a total of two minutes in one bout.

International styles: Freestyle and Greco-Roman.

Instantaneous fall: Not a fall, but the simultaneous touch of both shoulders by either wrestler, two points for the opponent.

Judge: One of the officials, seated across from the mat chairman and timer. The judge assists the referee, awards points and keeps score.

Junior: Internationally, a wrestler in the 18-20 age group. A wrestler 17 may enter with a medical certificate. Nationally, a high school wrestler attending grades 9, 10, 11 or 12 during the school term of the event (or immediately preceding a summer event), and must not turn 20 years old before September 1 of the year of the event, other rules apply.

Jury: The officiating team (referee, judge, mat chairman).

Jury of Appeal: The protest committee.

Kids: A division of USA Wrestling for wrestlers 14 and younger.

Kilogram: A weight of 2.2046 pounds, abbreviated "kg."

License: A document of eligibility, for wrestlers and officials.

Mandatory rest: A wrestler must be allowed at least 15 minutes after a bout before he/she can compete again.

Mat chairman: Chief of the three-man officiating team for any bout. He/she decides on the score or action when the referee and judge disagree.

Mat official: An official qualified to serve as a referee-judge.

Media coordinator: The person responsible for providing information to the press.

Medical alert: A document for communication between the medical staff and pairing staff.

Medical certificate: Written statement from a physician that a contestant is capable of competing.

Medical examination: Immediately preceding the first weigh-in, a check of each wrestler for skin infections or contagious disease.

Medical liaison: A pairing official assigned to communicate with the medical staff and to track all the medical alert forms.

Medical officer: A physician, trainer or other medical professional who treats injuries suffered by the contestants.

Modifications: Variations in the FILA rules adopted by USA Wrestling for domestic competition and applied to specific age groups.

National federation: USA Wrestling, or its equivalent in other countries, the national governing body.

National Wrestling Hall of Fame & Museum: The national museum of wrestling history, located in Stillwater, Oklahoma.

Olympic division: The 20-and-over age group. Wrestlers 18-19 are accepted with a medical certificate, 17 for Women's Senior Level. Also called Open or Senior division.

On deck: Two wrestlers called to the mat where a bout is in progress, to prepare themselves for the next bout on the same mat.

Opponent number: A symbol on the pairing chart telling each wrestler the draw number of his/her next opponent.

Order of weights: A chart showing the order in which weight classes will be called during the session, and the number of rounds likely for each.

Outstanding wrestler: An award to the contestant chosen the most skilled competitor in the event.

Overtime (Extra Time): An extension of the bout when time elapses with the score tied, or when the leading wrestler has not scored three technical points.

Paddles: Red, white and blue scoring devices, similar to table tennis paddles, used by the judge and mat chairman to indicate their decisions.

Pairing chart: The chart upon which the pairing official records the names, draw numbers and affiliations of the contestants, their scheduled bouts and results of the competition.

Pairing master: A senior pairing official sufficiently skilled to direct tournament operations and to present clinics.

Pairing official: An official competent to pair the contestants, record the results and carry out responsibilities assigned by a pairing master.

Pairing teams: Sets of two pairing officials, working together to conduct one or more weight classes, groups or age divisions.

Par terre: When both contestants are wrestling down on the mat, literally "on the ground."

Passivity zone: A 1-meter wide band inside the edge of the mat. Upon hearing "Zone!" from the referee, the wrestlers must work toward the center of the mat.

Place square: The space at the right end of each contestant's line on the pairing chart, where a number is written to denote the place earned.

Pool: Group.

Positive points: Classification points.

Preliminary rounds: Elimination rounds.

Presentation of awards: A ceremony during which wrestlers receive medals, trophies and other recognition of their achievements.

Protection area: The section of the mat that is out-of-bounds.

Protest: A formal appeal for reversal of a decision, claiming an error.

Red card: Expulsion of a coach from the rest of the tournament for unsportsmanlike behavior. Preceded by a yellow card (warning).

Red dot: A symbol on the pairing and wall charts to indicate that the wrestler wears a red singlet in his/her next bout.

Red pool: Group A, the wrestlers with odd draw numbers. In the finals, these wrestlers wear red singlets.

Referee: The official who conducts the bout on the mat, starting and stopping action with the sound of his/her whistle, and signalling his/her decisions on points, position and passivity to the judge and mat chairman.

Registration: The paperwork of entering an event, payment of entry fees, etc.

Release: Announcement, on authority of the chief pairing master, that all the wrestlers in a weight class may leave the arena until the next session, or to attend weigh-ins.

Re-pair: To restructure the pairing for a round after a withdrawal.

Reverse bye: A bye that is taken away from the bottom man on the list and awarded to another wrestler, only done to make it possible to pair more bouts in the next round.

Reverse score: Standard notation of loss by decision. Example, 3-8.

Round: A series of bouts involving all the wrestlers in a weight class or group, once each. If there is an odd number of contestants, one of them receives a bye.

Round-robin: Group finals, competition among three wrestlers remaining in a group, each meeting the other two regardless of the outcome of a single bout.

Runner: A person who carries bout sheets between the announcer and the mats.

Scoreboard: An unofficial means of showing the score of a bout to the spectators.

Seeding: Pre-tournament ranking of contestants by past achievement, so that they may be separated in the draw.

Senior: Another name for the Olympic or Open division, ages 20-up.

Separation: A planned procedure for placing contestants in different areas of the pairing chart, based on seeding, club or state affiliation, or a combination of these factors.

Session: A time period which spans one or more rounds of competition. Example, afternoon session.

Setup (floor): Preparation for the event, laying out and cleaning mats, arrangement of tables and chairs, head table, scales, etc.

Setup (pairing): Preparation of pairing charts, wall charts, bout sheets and other paperwork necessary to start the competition.

Single round-robin: An event where each weight is conducted as one group, and the round-robin determines the final placing.

Singlet: A one-piece uniform worn by the wrestler.

Singlet colors: For each bout, one wrestler is instructed to wear a red singlet, the other a blue singlet.

Slam: Throwing an opponent down with unnecessary force, without accompanying him to the mat. May be considered brutality. A slam is illegal in Kids competition.

Slipped throw: An unsuccessful attempted throw from standing or par terre. Also can apply to a gut wrench.

Special bout: A bout required to break a tie between two beaten wrestlers who have not yet wrestled each other.

Standard notations: A series of recording practices used and recognized on wrestling forms and charts nationwide.

Start sheet: A document assigning a series of bouts to specific mats. Seldom used in the USA, except for international events.

Team leader: The top-ranked delegate of a team.

Team scoring: The ranking of clubs, states or other teams according to points awarded for the success of their wrestlers.

Technical fall: A slang term for victory by technical superiority.

Technical points: Points scored by the wrestlers for actions and holds during a bout. Penalty points also are technical points.

Technical superiority: A victory on points, by a margin of 6 or more. The bout is stopped as soon as significant action ceases.

Time bout ended: The time of day, recorded on the bout sheet so that the mandatory rest period can be determined.

Time of bout: The actual elapsed time of competition. The time of a fall or technical superiority would be less than five minutes. The time of a decision would be 5:00, and overtime bout could be shown as 5:17.

Timer: The person who operates the clock for a bout.

Touche: French word for fall. The referee pronounces this word to “count” the time for a fall, about one-half second.

Total wrestling: The concept that both wrestlers must give maximum effort at all times.

Tournament operations: All the phases of planning and conducting a competitive event.

Universal wrestling: Use of a wide range of techniques and holds.

University: USA Wrestling division for wrestlers ages 18-24 and whose class has graduated from high school.

USA Wrestling: The national governing body and the sport’s delegate to the U.S. Olympic Committee and to FILA.

USWOA: U.S. Wrestling Officials Association, the national organization of mat and pairing officials.

Wall charts: Large posters, duplicates of the pairing charts, maintained for the information of wrestlers, coaches and spectators.

Weigh-in: A preliminary to competition, where the wrestler steps on the scale to certify that his/her weight does not exceed the limit for the class in which he/she is entered.

Weigh-in card: A card bearing the wrestler's name, weight class and other information, which serves as the link among registration, weigh-in, drawing of lots and pairing.

Weighmaster: The person who directs the weigh-in.

Weight classes: Divisions in pounds or kilograms, whereby wrestlers are grouped by size for competition.

Work sheet: A "trial" document used by the pairing official for calculations before making entries on the pairing chart.

World Cup: Annual dual meet competition among teams from different continents.

Yellow card: A warning given by the officials to a coach whose behavior is unsportsmanlike.

COUNTRY CODES

In international competition, the countries are identified by three-letter codes, used on all pairing, results and programmes (not complete).

Afghanistan	AFG	Great Britain	GBR	Niger	NIG
Albania	ALB	Greece	GRE	Nigeria	NGR
Algeria	ALG	Guatemala	GUA	North Korea	PRK
Angola	ANG	Guam	GUM	Norway	NOR
Amer. Samoa	ASA	Guinea	GUI	Pakistan	PAK
Argentina	ARG	Guinea-Bissau	GBI	Palestine	PLE
Armenia	ARM	Honduras	HON	Panama	PAN
Australia	AUS	Hungary	HUN	Peru	PER
Austria	AUT	Iceland	ISL	Philippines	PHI
Azerbaijan	AZE	India	IND	Poland	POL
Bangladesh	BAN	Indonesia	INA	Portugal	POR
Belarus	BLR	Iraq	IRQ	Puerto Rico	PUR
Belgium	BEL	Iran	IRI	Romania	ROM
Benin	BEN	Ireland	IRL	Russia	RUS
Bolivia	BOL	Israel	ISR	San Marino	SMR
Bosnia-Herzeg.	BIH	Italy	ITA	Saudi Arabia	KSA
Brazil	BRA	Ivory Coast	CIV	Senegal	SEN
Burkina-Faso	BUR	Japan	JPN	Slovak Rep.	SVK
Bulgaria	BUL	Jordan	JOR	Slovenia	SLO
Cameroon	CMR	Kampuchea	KAM	Somalia	SOM
Canada	CAN	Kazakhstan	KAZ	South Africa	RSA
Albania	ALB	Kenya.	KEN	Spain	ESP
Cent. African Rep.	CAF	Kirghizistan	KGZ	Sri Lanka	SRI
Chad	CHA	Korea	KOR	Sudan	SUD
Chile	CHI	Latvia	LAT	Sweden	SWE
PR of China	CHN	Lebanon	LIB	Switzerland	SUI
Colombia	COL	Lithuania	LTU	Syria	SYR
Congo	CGO	Luxembourg	LUX	Tadjikistan	TJK
Costa Rico	CRC	Macedonia	MKD	Taiwan	TPE
Croatia	CRO	Madagascar	MAD	Tanzania	TAN
Cuba	CUB	Mali	MLI	Thailand	THA
Cyprus	CYP	Malta	MLT	Tunisia	TUN
Czech Republic	CZE	Mauritania	MTN	Turkey	TUR
Denmark	DEN	Mauritius	MRI	Turkmenistan	TKM
Dominican Rep.	DOM	Mexico	MEX	Ukraine	UKR
Ecuador	ECU	Moldova	MDA	United States	USA
Egypt	EGY	Mongolia	MGL	Uruguay	URU
El Salvador	ESA	Morocco	MAR	Uzbekistan	UZB
Estonia	EST	Namibia	NAM	Venezuela	VEN
Finland	FIN	Nauru	NAU	Vietnam	VIE
France	FRA	Nepal	NEP	Virgin Islands	ISV
Gambia	GAM	Netherlands	NED	Western Samoa	SAM
Georgia	GEO	New Zealand	NZL	Yemen	YEM
Germany	GER	Nicaragua	NCA	Yugoslavia	YUG
Malaysia	MAS	Aauru	NAU	Zaire	ZAI
Palau	PAL	Paraguay	PAR	Solomon Is.	SOL
FS of Micronesia	FSM	Qatar	QAT	Suriname	SUR
Netherl, Antilles	AHO	Aruba	ARU	Serbia	SER
Montenegro	MNE				

A Guide to Pairing

For many USA Wrestling sanctioned events in 2012, the use of computer assisted bracketing will be implemented. Even though much of the pairing procedures and policies apply in general, there may be situations that necessitate a modification or revision to the policies and procedures as they come to light.

This also includes the use of draw numbers, where computers will be substituted to complete the random separation of wrestlers versus the use of numbers drawn by the contestants.

In the international styles of wrestling, the system of matching the contestants, recording results and determining the course of the competition is a deployment of numbers known as pairing.

At the outset of a tournament, each contestant draws a number, or one is assigned to him. If any consideration is given to a wrestler's past achievements, or to his/her state or club affiliation, it is done at this point. Once competition has begun, the pairing formula matches contestants only by their draw numbers, and there is no further attention to the identity of the wrestlers, or their level of success.

During the 1991s, as FILA introduced the concepts of total wrestling, massive changes occurred in the rules and philosophy of the sport, bringing major improvements in tournament procedures. The rules now provide a true championship final in each weight class in contrast with earlier procedures.

Changes have continued into the new century and FILA continues experimenting with forms of line bracketing as an alternative to the vertical pairing format in use for nearly half a century.

Modifications

FILA conducts age group events, but has only a few special rules for youth competition. USA Wrestling, on the advice of its sport committees and sport science staff, has adopted modifications to the FILA rules for specific age groups or levels of competition in this country. USA Wrestling applies modifications to age limits, weight classes, drawing of lots, pairing procedures, separation of contestants, use of the pool system, and on-the-mat competitive rules.

Beginning in 2006, FILA changed to a modified line bracket format for all of its championships, with double elimination for the gold and silver medals and two consolations for third. All places below fifth are, in general, determined by classification points. USA Wrestling does not plan to use this format for its domestic events.

USA Wrestling national championships in the University, FILA Junior World and Veteran's Divisions will be conducted under a double eliminations format long used in this country by many sports. The two undefeated wrestlers compete for first and second places, but until a wrestler has been beaten twice, he remains in contention for the bronze. The double elimination format also will be employed for USA World Team Trials in the University and FILA Junior World Divisions. The Senior Division will use a modified line bracket system for that divisions National Championships. Senior World Team Trials procedures are explained in a separate document available from USA Wrestling.

The Women's University and Junior World Divisions will utilize the two pool vertical system at National Championships and World Team Trials.

USA Wrestling will continue to conduct its Freestyle and Greco-Roman Junior Nationals and Cadet Nationals, with their huge entry totals, under the vertical pairing format.

DOUBLE ELIMINATION BRACKETING

Double elimination, with seeding and separation of wrestlers of proven skills, is an alternative to the vertical pairing method, and to FILA's two bout elimination process.

Double elimination guarantees at least two bouts for each contestant. However, a wrestler who loses before reaching the finals can place no higher than third, so half of all the bouts are among contestants who are no longer in the gold medal race. This format's original attraction for wrestling was its emphasis on participation, particularly for athletes not of championship caliber.

The number of bouts in a double elimination bracket is about the same as the number of bouts for a vertical pairing chart.

Any double elimination procedure offers the possibility of a rematch of wrestlers who have met in an early round. Each bracket is developed to delay the possibility of rematches as long as possible.

A 64-man bracket contains two more rounds than a 32-man bracket, which in turn contains two more rounds than a 16. The first order of business is to reduce all brackets to the same level. When the event reaches the quarter finals, all weight classes should have the same number of contestants, and the same number of bouts.

Setup Procedures

1. Carefully count the number of entries in each weight class; determine size of bracket to use - 8, 16, 32, or 64 bracket.
2. Determine the number of byes and place the byes on the proper lines, using the chart at the top of page 95. The byes can be written on the bracket as soon as we know the total number of entries in any weight class.
3. Make up post-it notes indicating 1st, 2nd, 3rd, and 4th quarters, AND "Upper" and "Lower" half brackets (six post-its total). Arrange post-its on work table.
4. Pull weigh-in cards of seeded wrestlers; place in the appropriate quarter as indicated on the chart on page 95. (Example: Place weigh-in card of #1 seed under the 1st quarter post-it, #2 seed under 3rd quarter post-it, etc., until all seeds have been placed.
5. Separate and stack all remaining cards by club/team.
6. Check to see if any seeded wrestler is a member of a club or team from #5 above. All non team member weigh-in cards may be placed in an unassigned deck of weigh-in cards.
7. You now have cards of wrestlers from the same teams or clubs of seeded wrestlers. The seeds remain in their assigned quarter brackets. Club or teammates are distributed in the bracket according to: (Place cards under appropriate post-it note.)

Two Contestants:

If one is seeded, his/her teammate is assigned to the other half of the bracket. Place card under half bracket post-it.

Three Contestants

a. If one is seeded, both of the remaining club members are assigned to the half bracket away from their seeded teammate, in opposing quarters, low draw number first. Place cards under appropriate post-it. (Quarter post-it)

b. If two are seeded and separated, the remaining member is assigned to the lowest numbered quarter-bracket away from a teammate.

c. If two are seeded, but in the same half, the remaining club member's card is assigned to the opposite half. Place card under that half bracket post-it note.

Four Contestants

a. If one is seeded, the remaining club members are assigned alternately, starting with the low draw number in the first quarter in the half opposite the seeded club member, until there is one club member in each quarter-bracket. The fourth member (highest draw number) will be assigned the quarter bracket away from his/her seeded teammate, but in same half bracket.

b. If two are seeded and separated, the remaining members with the lowest draw number is assigned to the upper half and highest draw number to the lower half, in quarter-brackets away from their teammates.

c. If two are seeded, but in the same half, the two remaining members with the lowest and highest draw numbers are placed in the opposite half, in opposing quarter-brackets, low draw number first available quarter.

Five or More Contestants

a. For five only: Follow procedures above for four. The remaining member will be placed in the unassigned deck. Keep record of all clubs/teams with five or more contestants.

b. For Five and Six: Follow procedures for four above. The lowest draw number (#5 contestant) is assigned to the "Upper" half bracket, and the highest draw number (#6 contestant) is assigned to the "Lower" half bracket.

c. For Five to Seven or more: Follow procedures above for four. Five, six, seven, eight, etc. from same team/club, place in draw number order, lowest to highest. Distribute as follows: Five in 1st quarter, six in 3rd quarter, seven 2nd quarter, eight in 4th quarter, nine in first quarter, etc.

8. To separate club/team members with more than one contestant, **but no seeds**, follow these procedures: (Place cards under appropriate post-it note.)

Two Contestants

The club/team member with the lower draw number is assigned to the upper half of the bracket and his/her teammate to the lower half. Place cards under those notes.

Three Contestants

The club member with the low draw number of the three is assigned to the upper half, the high draw number to the lower half, and the other returned to the unassigned deck.

Four Contestants

Place the four contestants in draw number order, lowest to highest, and assign to quarter brackets. Lowest draw number to 1st quarter, next draw number to 2nd quarter, etc.

Five or More Contestants

- a. Follow procedures above for “Four Contestants”.
 - b. Refer to **a**, **b** and **c**. from “Five or More Contestants” under #7 above.
9. Note how many weigh-in cards are under each quarter post-it note and how many byes are written in for the quarter.
 10. Arrange unassigned weigh-in cards in draw number order, lowest to highest.
 11. Count number of cards under Upper half post-it and mathematically add number of cards under 1st and 2nd quarter post-its and number of byes written in on upper half of bracket; subtract this number from the number of lines for the upper half bracket to determine the number of cards to be taken from the unassigned cards to fill the upper half bracket. Select that number of cards from the unassigned cards and place with the cards under the Upper half post-it note and place in draw number order, lowest to highest.
 12. Now, take the previously assigned 1st quarter cards and add the necessary number of Upper half cards from #11 above to fill first quarter. Put all these cards in draw number order, lowest to highest, and place in order on work table.
 13. The remaining cards under the Upper half post-it should fill the 2nd quarter. Put these cards and the previously assigned cards to the 2nd quarter in draw number order, lowest to highest, and place on work table.
 14. Repeat procedures #11-#13 for lower half of bracket.

Movements of Club/Teammates

15. Check each quarter bracket to see if there are teammates within same quarter.
16. If there are two wrestlers from same club/team in the same 1/8 or 1/16 within a quarter bracket, move the lower draw number to a different upper 1/8 or 1/16 within that quarter bracket. If the lower draw number cannot be moved up, move the higher draw number down within that quarter bracket.
17. If there are two seeds in the same 1/8 or 1/16 within a quarter bracket, move the lower draw number to a different upper 1/8 or 1/16 within that quarter bracket. If the lower draw number cannot be moved up, move the higher draw number down within that quarter bracket.
18. Viewing the actual bracket sheet to be used for the weight class, number the weigh-in cards, giving each the number of the line where that name will be placed. Be sure to skip line numbers where “byes” have been assigned.
19. On the numbered bracket sheet, write name of contestant and club/team affiliation. Club seed is optional.
20. On your flow chart, number all the bouts in the tournament, then plan mats and sessions. Post the order of weights and show what rounds and what bouts will be wrestled in each weight class during the entire session.

Total bouts can be determined by using the following formulas:

For the whole tournament, eight places: Entries minus the number of weights, then doubled, equals the total number of bouts.

For one weight, eight places: Entries minus 1, doubled = bouts.

Note that both totals, because they are doubles, must be even numbers. You may have an odd number of bouts in one round, but if they don't even up quickly, look for a mistake.

Keep all bout numbers on the flow chart to maintain the proper order of championship and consolation rounds. When championship losers are to meet consolation winners in the same session, it is important to run both sides of the bracket at the same time, to equalize rest periods. The flow chart is designed to get all brackets down to the same number of rounds by the quarter finals.

Number every bout in the tournament in red on the brackets and wall charts. The wrestler on the top line always wears red.

Mark the seeds, in black, at the left of the wrestlers' names.

- ① Bruce Baumgartner, NYAC, or
1--Bruce Baumgartner, NYAC

Number each wrestler in each weight class one through the number of wrestlers entered. Carry the number with the wrestler's name when recording, particularly in the consolation rounds. It is easier to track his/her name when writing bout sheets. It also prevents mistakes if two wrestlers have the same last name.

Write the result, in black, under the winner's name as he advances to the left or right.

One of the drawbacks of double elimination bracketing is that it is extremely difficult to "pig-tail" an extra (17th, 33rd or 65th) entry into the bracket, because you have to "pig-tail" in two additional rounds. The cross-bracketing is quite complicated, as is the process of squeezing two extra "rounds" into the flow chart.

The best solution is to use the next larger bracket and lots of byes.

USA Wrestling now has double elimination brackets all the way to 128.

Rule for cross-bracketing in the Consolation Semi-Finals round. For any 8, 32 or 128 person bracket, the losers of the Championship Semi-Finals cross bracket into the Consolation Semi-Final round. For any 16 or 64 person brackets, the losers of the Championship Semi-Finals drop straight back to the Consolation Semi-Final bout in their same half of the bracket.

FS
Division
127.8
Weight

PIONEER OPEN
Event

Date

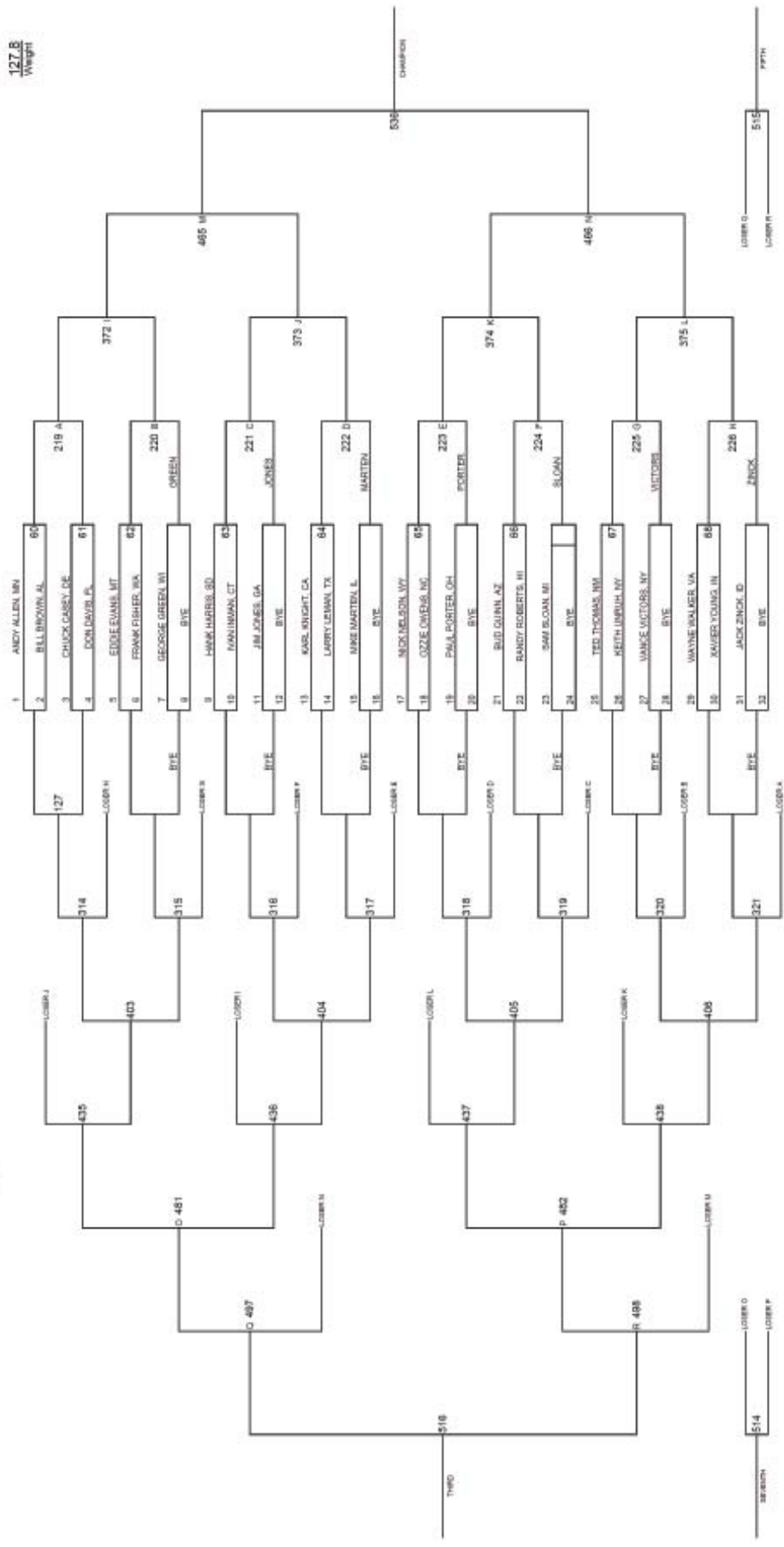

WHERE TO PLACE THE BYES

64 Brackets				32 Bracket				16 Bracket	
Bye	Line	Bye	Line	Bye	Line	Bye	Line	Bye	Line
1	2	17	61	1	2			1	2
2	63	18	29	2	31			2	15
3	34	19	45	3	18			3	10
4	31	20	13	4	15			4	7
5	18	21	53	5	10			5	6
6	47	22	22	6	23			6	11
7	50	23	38	7	26			7	14
8	15	24	6	8	7				
9	10	25	57	9	6				
10	55	26	26	10	27				
11	42	27	43	11	22	8 Brackets			
12	23	28	11	12	11	Bye	Line		
13	8	29	19	13	30	1	2		
14	40	30	51	14	13	2	7		
15	27	31	4	15	20	3	6		
16	59								

PLACEMENT OF SEEDED WRESTLERS (in order)

8 man Bracket - 1, 8, 5, 4

16 man Bracket - 1, 16, 9, 8, 5, 12, 13, 4

32 man Bracket - 1, 32, 17, 16, 9, 24, 25, 8, 5, 28, 21, 12

64 man Bracket - 1, 64, 33, 32, 17, 48, 49, 16, 9, 56, 41, 24

128 man Bracket - 1, 128, 65, 64, 33, 97, 96, 32,17,82

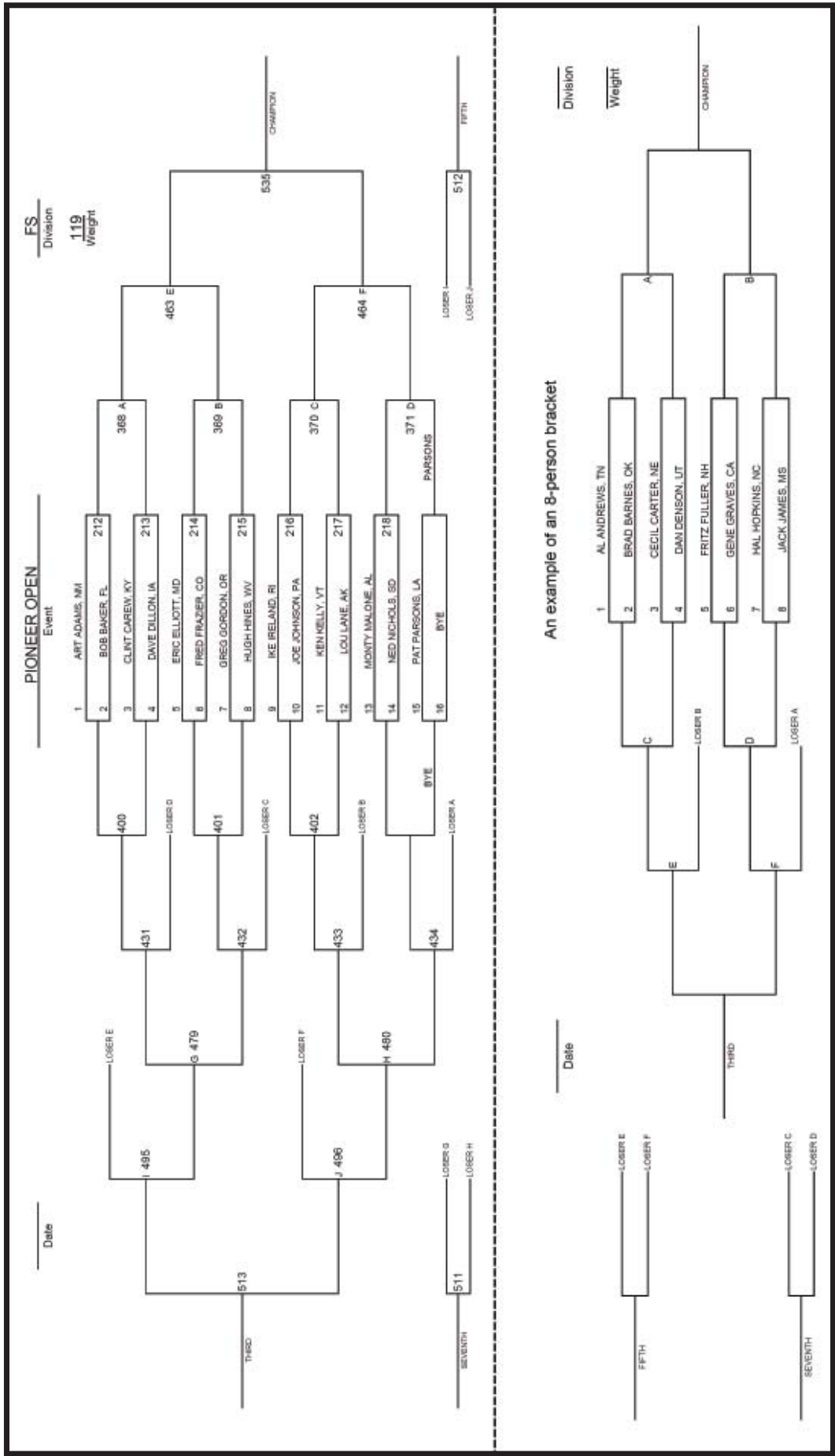

BYES AND BOUTS, BASED ON ENTRIES

The chart below shows the number of byes and bouts in the first three rounds of four different sizes of brackets. Note that the 64 bracket wrestles first, then wrestles Round II and consols while the 32 bracket is getting started. The 64 bracket wrestles Round III (all consols) before action resumes in the 32 bracket and begins in the 16 bracket. The 8 bracket doesn't start until Round VI.

64 Bracket					32 Bracket				
Ent	Bye	I	II & c	III	Ent	Bye	II	IV & c	V
64	0	32	16+16=32	16	32	0	16	8+8=16	8
63	1	31	16+15=31	16	31	1	15	8+7=15	8
62	2	30	16+14=30	16	30	2	14	8+6=14	8
61	3	29	16+13=29	16	29	3	13	8+5=13	8
60	4	28	16+12=28	16	28	4	12	8+4=12	8
59	5	27	16+11=27	16	27	5	11	8+3=11	8
58	6	26	16+10=26	16	26	6	10	8+2=10	8
57	7	25	16+9=25	16	25	7	9	8+1=9	8
56	8	24	16+8=24	16	24	8	8	8+0=8	8
55	9	23	16+7=23	16	23	9	7	8+0=8	7
54	10	22	16+6=22	16	22	10	6	8+0=8	6
53	11	21	16+5=21	16	21	11	5	8+0=8	5
52	12	20	16+4=20	16	20	12	4	8+0=8	4
51	13	19	16+3=19	16	19	13	3	8+0=8	3
50	14	18	16+2=18	16	18	14	2	8+0=8	2
49	15	17	16+1=17	16	17	15	1	8+0=8	1
48	16	16	16+0=16	16					
47	17	15	16+0=16	15					
16 Bracket					8 Bracket				
Ent	Bye	IV	VI & c	VII	Ent	Bye	VI	VIII & c	IX
46	18	14	16+0=16	14	16	0	8	4+4=8	4
45	19	13	16+0=16	13	15	1	7	4+3=7	4
44	20	12	16+0=16	12	14	2	6	4+2=6	4
43	21	11	16+0=16	11	13	3	5	4+1=5	4
42	22	10	16+0=16	10	12	4	4	4+0=4	4
41	23	9	16+0=16	9	11	5	3	4+0=4	3
40	24	8	16+0=16	8	10	6	2	4+0=4	2
39	25	7	16+0=16	7	9	7	1	4+0=4	1
38	26	6	16+0=16	6					
37	27	5	16+0=16	5					
36	28	4	16+0=16	4					
35	29	3	16+0=16	3					
34	30	2	16+0=16	2					
33	31	1	16+0=16	1					

The examples on pages 95 and 97 show how the brackets should look before any wrestling has begun. Byes carried out to the left clearly show situations where no bout is to be wrestled.

DOUBLE ELIMINATION FLOW CHART												
Weight	Number of Entries	I R/64 only	II R/32 + cons	III cons only	IV R/16 + cons	V cons only	VI QF + cons	VII cons only	VIII SF + cons	IX cons semis	X Medals	XI Finals
54 KG 119 lbs	15	SKIP	SKIP	SKIP	7 212-218		4 368-371 0 400-402 4		2 463-464 4 479-480 2		511-513 495-496 2	535 3
58 KG 127.8 lbs	25	SKIP	9 60-68		8 219-226 0 227 1 314-321 8		4 372-375 4 403-406 4		2 465-466 4 481-482 2		514-516 497-498 2	536 3
63 KG 138.8 lbs	41	9 1-9	16 69-94		8 228-235 9 236-243 8		4 376-379 4 407-410 4		2 467-468 4 483-484 2		517-519 499-501 2	537 3
69 KG 152 lbs	58	28 10-35	16 95-100 101-110 10		8 244-251 174-189 16 252-259 8		4 380-383 4 411-414 4		2 469-470 4 485-486 2		520-522 501-502 2	538 3
76 KG 167 lbs	50	13 36-53	16 111-126 127-128 2		8 260-267 190-205 16 268-275 8		4 384-387 4 415-418 4		2 471-472 4 487-488 2		523-525 503-504 2	539 3
85 KG 187 lbs	38	6 54-59	16 129-144		8 276-283 206-211 6 284-291 8		4 388-391 4 419-422 4		2 473-474 4 489-490 2		526-528 505-506 2	540 3
100 KG 220 lbs	30	SKIP	14 145-158		6 292-299 0 300-305 6 364-361 8		4 392-395 4 423-426 4		2 475-476 4 491-492 2		529-531 507-508 2	541 3
125 KG 275 lbs	22	SKIP	6 159-164		8 306-313 0 362-367 6 427-430 4		4 396-399 4 427-430 4		2 477-478 4 493-494 2		532-534 509-510 2	542 3

2(279-8) = 542 Bouts

Round VI -- QF + cons -- Wrestle in weight class order at the same time on separate mats
 Round VIII -- SF + cons -- Wrestle in weight class order at the same time on separate mats

THE FLOW CHART

Just as it is in vertical pairing tournaments, the Flow Chart is the Chief Pairing Master's most valuable tool for double elimination events. Tournament operations procedures and personnel described in detail on pages 116-131 also are appropriate in bracketed events.

The principal drawback of the double elimination tournament is that setup procedures are more difficult and take a lot more time. This puts more pressure on the man or woman with the clipboard.

The principal advantage is that Americans in all sports are more familiar with brackets than any other form of pairing. It's easy to determine the next opponent if you win, or if you lose. The wrestler on the top line always wears red. And every bout of the tournament can be numbered before the first bout is wrestled. That's a big help in planning the session and the use of mats.

After the number of entries in each weight class has been counted carefully, enter the data on the flow chart. Add up the total entries and calculate the total number of bouts. Put the pairing teams to work placing the byes and drawing open lines for the seeds, according to the charts on page 96.

The Chief Pairing Master should assign a senior assistant or two to supervise these tasks and to help the pairing teams move on to separation by clubs, drawing lines for those separated, then filling in the blank lines with all the other wrestlers.

The Chief must concentrate on the Flow Chart and get everything right the first time. The two major uses of the Flow Chart are:

1. To schedule the larger weight classes first, until all weights reach the same number of contestants, and
2. To schedule championship and consolation rounds together when wrestlers from both meet each other in the next round.

Referring to the chart on page 99, write the number of bouts in each weight of the 64-brackets in the upper left-hand corner of the appropriate squares in the **I** column.

In the **II** column, write the number of championship bouts in the upper left-hand corner. The 32-brackets start here, so write the number of bouts in the upper left (there are no consolations yet).

In the **III** column, the only bouts are in the 64-brackets, all consolations, so they go in the lower right corner of each square.

Continue into the **IV** column, bringing in the first bouts from the 16 brackets, and on to the **V** column. Weight classes from the 64-brackets now will have the full set of bouts, 8+8c in **IV** and 8c in **V**.

Continue to fill in the squares for every round, right on through the finals. You already have calculated the number of bouts in the entire tournament. As a further check, calculate the number of bouts in each weight. Add each weight across the chart. All the totals should be even numbers. Add those totals and the figure should match your original calculation of total bouts for the tournament.

Add each column for a further check of your bout numbers. Number every bout in every round. A last-minute addition must replace the last bye. (In the chart on page 95, a 26th entry would go on line 26.) Remember the method of inserting bouts such as "81-A" and the notation "no bout 70" explained on page 127.

Now decide how many bouts and mats you need each session.

Give the media coordinator a copy of your completed flow chart. He will be able to label the proper results "first round, second round, first round consolation," etc., even though the weight class may not start until **II**, **IV** or even **VI** on your flow chart.

THE VERTICAL PAIRING FORMAT

To establish a true championship bout, without the possibility that two wrestlers will meet twice in the same tournament, the vertical pairing format calls for a "pool" system, whereby each weight class is divided into two groups.

Each pool, or group, is carried to a round-robin conclusion, called "group finals." Place winners from the two groups then are paired in bouts to determine final placing in the event. The winner of the two groups compete for the championship, the loser placing second. The runners-up compete for third and fourth, etc.

During the preliminary rounds leading to the group finals, a wrestler is eliminated only by two defeats (or by injury or certain types of disqualification). The *margin* of victory or defeat does not affect the progress of the competition. Classification points earned by the wrestlers come into play only as tie-breakers.

WEIGH-INS

FILA rules call for a single weigh-in for the whole tournament, the night before competition begins, for 30 minutes. USA Wrestling reserves the right to set the time and duration of weigh-ins for all domestic competition and, for age-group events, to conduct second and subsequent weigh-ins, and permit a daily tolerance. Generally, second weigh-ins will be for 60 or 30 minutes the next morning prior to competition.

The Weigh-in Card

At international events, where numbers are small and each country's entries are known well in advance, a weigh-in chart is posted near the scale, easily visible to all wrestlers and coaches. The chart lists each wrestler and his/her country code (JPN, CUB, USA, etc.) When the wrestler weighs in and draws his/her number, it is posted beside his/her name and country code for all to see.

In the large tournaments of the USA, use of the weigh-in card speeds paperwork. Each contestant is given a weigh-in card at registration. He fills it out, including the weight class he/she intends to wrestle, has his/her draw number indicated on the card and will then take it to the weigh-in area at the appropriate time. Each contestant shall have a draw number, which will be recorded at registration, and written on his/her weigh-in card. This process will be supervised by a drawmaster, or designee. Each athlete shall then submit to a medical check. The athlete will then be directed by the weighmaster to approach the scale and weigh-in. If he/she makes the listed weight, the weighmaster at the scale marks the card. If the wrestler fails to make weight, the weigh-in card is **not** to be returned to him/her until he/she does, or until he/she changes to another weight and completes the procedure. This is the standard operation for entering the tournament. At the close of weigh-in, all cards are delivered to the chief pairing master.

The processed weigh-in card is the link between the registration desk and the pairing staff.

For second and third weigh-ins, either the cards are returned to the wrestlers remaining in the tournament, or the weighmaster is provided a list of those eligible to weigh in.

DRAWING OF LOTS

(In general and does not apply to all age groups)

Each wrestler draws a number at time of registration which is recorded on the weigh-in card. For the Senior Division and Kids Division Regional Championship events drawing of numbers occurs prior to medical check and prior to approaching the scale. The names in each weight class are listed in numerical order, from the smallest number to the largest.

(If weigh-in cards are used, the cards are arranged in numerical order)

The contestants then are renumbered consecutively, filling in any gaps. In this example, 13 wrestlers are entered, but only 11 weigh in.

Where computer assisted bracketing is utilized, drawing of lots will be done by random selection by a computer.

EXAMPLE

Allen draws No. 4	Because two wrestlers	1 Evans staysNo. 1
Brown3	failed to weigh in, two	2 Harris 2
Casey9	numbers were not	3 Brown 3
Davis7	drawn, in this case	4 Allen 4
Evans1	No. 6 and No. 11.	5 Lemon 5
Fisher10		7 Davis becomes 6
Green12		8 Jones becomes 7
Harris2	The wrestlers are listed	9 Casey becomes 8
Jones 8	in numerical order	10 Fisher becomes 9
Knight13	then are renumbered	12 Green becomes 10
Lemon5	consecutively	13 Knight becomes 11

Once the assigned numbers are continuous, the wrestlers with odd numbers are placed, in order, in Group A, sometimes called the “red” pool. The wrestlers with even numbers are placed in Group B, the “blue” pool. If the total does not divide equally, the odd man always goes in Group A. Competition within the groups now is conducted as two separate, round-robin tournaments.

Group A	Group B
1 Evans	2 Harris
3 Brown	4 Allen
5 Lemon	6 Davis
7 Jones	8 Casey
9 Fisher	10 Green
11 Knight	

For absolute security in the draw, there should be more numbers to be drawn than there are wrestlers to draw. This extends the element of chance to every wrestler, even to the last one, and acts as a safeguard against cheating, as when a wrestler tries to draw a “favorable” number away from certain opponents.

A big batch of numbers, well mixed, can be divided up at random at the draw number table. An athlete drawn to No. of 22 won’t know whether it is high, low, odd or even until all contestants have drawn numbers that have listed in order.

When the draw for each weight is completed, and pairing are established for the first round, each contestant has a permanent number for the entire competition. The number will not change.

To identify the contestants for spectators, each wrestler should have his/her own unique number. In the first weight, 101, 102, 103, etc., the second weight, 201, 202, 203, etc., the third weight, 301, 302, 303, etc. You are not limited to three digits. You may use 1101, 1102...1201, 1202...and 1301, 1302, etc.

Contestants thus can be identified on a printed program, and on matside scoreboards. In the pool system, contestants 101, 103, 105, etc., are in Group A, and 102, 104, 106, etc., in Group B of the same weight class. These numbers are entered on the pairing chart at the left of the contestants’ names. It is not necessary to repeat the full number all the way across. Contestants may be paired 1 vs. 3, 5 vs. 7, etc.

Seeding and Separation

In the USA, across a wide range of sports, it is customary to separate contestants of known ability, and to separate members of the same team, or representatives of the same locality. This is easy with the pool system, simply by ensuring that wrestlers with superior records (or those from the same area) fall into opposite groups.

The concept of seeding and separation often undermines the philosophy of chance, and allows individual judgment to override “luck of the draw.” Sometimes individual judgment is heavily biased. For its national championships, USA Wrestling has adopted specific procedures for the drawing of lots and the separation of contestants.

At the Senior Division nationals, where the achievements of world class athletes are well established, the top contestants are seeded and separated by an assigned committee. Even so, the numbers they draw at weigh-in are used to place them on the pairing charts. In other age groups, where comparative skills are difficult to measure, separation generally is by club or state affiliation.

These procedures can be adopted to regional, state or local events to a limited degree. It is important, however, to maintain the element of chance, using numbers actually drawn by or for the contestants prior to or at weigh-in, depending on the event. To separate two contestants, place the lower draw number of the two in Group A, the higher in Group B. For three contestants, place the lowest draw number in A, the highest in B, the other back in the unassigned deck. For four, deal alternately by number to A and B; for five, seven, nine, eleven contestants deal alternately by number to A and B, but place the last odd number in the unassigned deck. When all separations have been made, sort the remaining cards in numerical order and deal them alternately to Groups A and B. Then sort each pool in ascending order.

It also is possible to separate contestants within a group. But don't overdo the “seeding.” It is difficult to document the abilities of contestants from different areas. Leave quite a bit to luck of the draw.

It is established policy of USA Wrestling that representatives of the states, clubs and/or individual athletes may attend tournament setup sessions as observers. But credentials should be checked at the door, and attendance limited to those with legitimate interests.

To Pool or Not to Pool

The only purpose of the pool system is to present championship finals in each weight class, as well as bouts for other places. The weakness of the single round-robin tournament is that the best two wrestlers often meet in an early round, and there is no “final” bout for the spectators, for television cameras or for newspeople.

In many tournaments at the local level and those for younger contestants, true “finals” are not as important as steady progress of the competition. In such events, it doesn't make sense to keep half a dozen kids in one weight class sitting around for hours, miles away from home, while 40 kids in another weight wrestle down to finals.

The pool system is not required at all USA Wrestling sanctioned events. Local organizers may decide on a single round-robin format, and awards can be presented as they are earned. Procedures for regional and national events are set by the national office.

The pool system is employed only when there are six or more contestants. Some weights may be pooled and others not pooled in the same event, based on the number of entries.

PAIRING PROCEDURES

Except for unusual variations which sometimes arise late in a tournament, the principle of international pairing is simple. Contestants are listed in numerical order on the pairing chart. The basic concept is that the top man is paired with the first man below him/her whom he/she has not met. Each group is a separate competition, and is paired and recorded as though it were a separate weight class.

When there is an odd number of contestants, the wrestler on the bottom of the list receives a bye (does not wrestle) in that round, then becomes first on the list for the next round. This does not mean that you pair upward from the bottom--it means that No. 11, after receiving a bye, actually is listed above No. 1 for the next round and for the rest of the tournament.

The Work Sheet

USA Wrestling has developed forms for tournament operations, including a work sheet on which the pairing official can plot the next round before entering data on his/her pairing chart. When "moving a wrestler to the top," the numbers are manipulated on the work sheet, so that the original pairing chart need not be altered. If you've ever turned a pairing chart over to write on the back, or have picked up a blank bout sheet to plan the next round, the work sheet is what you need. Do the work sheet in pencil, the pairing chart in ink.

From the Top Down

The concept of pairing is to work down from the top of the list. Variations arise because the same two wrestlers do not meet twice in one tournament.

Whether you use pools (1, 3, 5, etc. ... 2, 4, 6, etc.) or a single round-robin (1, 2, 3, 4, 5, etc.), the procedures are the same. For the illustration, we will pair a single round-robin. Once the wrestlers are numbered and listed in order from the top to the bottom of the chart you are ready to pair the first round. It's always the same, and easy: 1 vs. 2, 3 vs. 4, 5 vs. 6, etc. If there is an even number everybody wrestles in the first round. If there is an odd number, the last athlete receives a bye and advances with no classification points.

The second round has two possibilities, one if we started with an odd number of wrestlers, another if we started with an even number.

Odd Number

If there are 11 wrestlers in the first round (or any odd number), start the second round list of numbers on your work sheet with the wrestler who drew the bye. Pair the second round, from the top: 11 vs. 1, 2 vs. 3, 4 vs. 5, etc. No. 10 receives a bye in the second round. Then he/she becomes top on the list for the third round, right above No. 11. No. 11 is up there to stay, until he/she is eliminated. He/she does not drop back to the bottom when No. 10 moves up. In fact, the third round starts 10 vs. 11, because they are atop the list and they haven't met.

Even Number

If there are 10 or 12 (or any even number) of contestants in the first round, there is no bye, no one is moved up and No. 1 remains at the top of the list. On the work sheet, pair from the top. No. 1 can't meet No. 2 (again), so he/she is paired with No. 3. Then No. 2 is paired with the next available wrestler, No. 4, and so on. If the number of wrestlers is exactly divisible by four, the whole second round works out smoothly (1-3, 2-4, 5-7, 6-8 . . . 13-15, 14-16). If the total is not divisible by four, we encounter the first variation.

Back Forcing

Suppose you have six contestants, an even number not divisible by four. No. 1 meets No. 3. No. 2 hasn't met No. 4, so that appears OK, but wait ... No. 5 then would be paired with No. 6, and they have met. So we turn to a variation called "back forcing." That means you have reached an impasse, and you must back up a notch to solve.

Leave No. 1 vs. No. 3 alone. Since you cannot pair No. 2 against No. 4 this round, try the next wrestler down the list and pair No. 2 against No. 5 that leaves No. 4 against No. 6, and it works, so you have the next round. In most cases, back forcing will change *only* the last bout you paired. Back forcing is applied to the "even" example which follows:

Even		Rd 1	Rd 2	Odd		Rd 1	Rd 2
				5 Green NY			
1	Evans MO	□	□	1 Harris VA	□	□	
2	Brown NJ	□	□	2 Allen CO	□	□	
3	Lemon CA	□	□	3 Davis TN	□	□	
4	Jones NC	□	□	4 Casey MI	□	□	bye
5	Fisher KS	□	□	5 Green NY	bye		
6	Knight WA	□	□				

Back forcing, of course, does not apply to the first round, but it may be needed in any other round, even one where there is an odd number of wrestlers and the bottom man on the list has a bye. Back forcing is not "pairing up from the bottom." Back forcing is a signal to back up until you solve the problem. Always pair from the top down.

Sometimes, near the end of a long list and in later rounds, back forcing is not quite as simple.

For example, the last four contestants on the list are Nos. 11, 14, 15, 16. Everything pairs smoothly to that point, and No. 11 hasn't met any of them. You try 11-14, but 15 and 16 have met. You try 11-15, but 14 and 16 also have met. You try 11-16 and 14-15. If that works, you have the pairing.

Another variation is more complicated, but rare. In the previous example, suppose none of those combinations for the last four wrestlers will work. Now you are "back forced" one more step up the ladder. Break up your last good pairing, so that you now have six wrestlers to pair. Say, that was 7-10. Now you have 7, 10, 11, 14, 15 and 16. Try the 7-11 combinations. No luck? Try the 7-14 combinations. You may wind up with something like 7-14, 10-15, 11-16.

You'll encounter a few more variations from time to time. Keep your Guide handy for reference. Use the work sheet and plan ahead, watching for potential problems and solutions.

The Double Bye

On rare occasions, when there are few wrestlers remaining in a weight class (usually four), there may have been so many bouts among them that it is impossible to pair all the wrestlers. You may have to award two byes in one round and wrestle only one bout. That one, as always, is paired from the top of the list.

For example, the only wrestlers left are Nos. 1, 6, 7 and 8, in order, and No. 6 has met all three opponents. Obviously, No. 6 must have a bye. From the top, No. 1 is paired with No. 7. that gives No. 8 a bye, too. For the next round

both byes move up. If all four wrestlers remain, the proper order is 6-8-1-7. A double bye often is followed by another in the next round.

The Reverse Bye

The bottom wrestler of an odd-number list must receive the bye, unless that makes it impossible to pair the other contestants, or a larger number of bouts can be paired if the bye is withdrawn. Only then does the bottom man lose his/her right to the bye.

Say you have five wrestlers, and a situation develops as it did in the previous paragraph. Don't give three byes in one round. Take the bye away from No. 9 and assign it to No. 8. That may solve the problem. If not, try No. 7 and move the bye up the list until you are able to pair the wrestlers. This is another form of "back forcing." Whoever receives this reverse bye moves to the top of the list for the next round, while No. 9 remains at the bottom. This situation is extremely rare.

Other Policies Regarding Pairing

In the case where two wrestlers are eliminated in the same round, the bout between them, if wrestled prior, shall determine which of the two wrestlers advances or is placed higher, depending on the circumstances. If the wrestlers have not met earlier, the criteria as currently used to determine the wrestler that advances or places higher shall be used. In all cases of three way ties or greater, the criteria and procedures currently used shall determine the outcome of the placing or advancement of athletes.

For events in which weigh-ins occur 2 hours prior to competition and the brackets are drawn well in advance the following procedures have been adopted:

1. If after the weigh-in, due to no-shows and/or failure to make weight, the number of competitors in a weight is less than 6, the weight classes shall be repaired using one pool.
2. If after the weigh-in, due to no-shows and/or failure to make weight, one pool in a weight class has only 2 competitors or less the weight class shall be repaired to evenly distribute the competitors using the draw numbers of the remaining competitors.
3. If after the weigh-in, due to no-shows and/or failure to make weight, one of two pools in a weight class will wrestle two or more rounds based on the formulas the weight class shall be paired to evenly distribute the competitors based on draw number.
4. See page 66 regarding forfeits (no-shows).

RECORDING (see pages 140-141)

Each round, the pairing official records on his/her chart the pairing, the bout numbers and the opponents' numbers. Singlet colors are indicated by placing a red dot in the next-round square of the wrestler who is to wear the red--always the first (top) wrestler of the two paired, although you must remember that the "top" wrestler may have the larger number. Start by putting the red dots on the work sheets. Bout sheets for the next round are prepared from the pairing chart, and are kept in order by use of bout numbers. Wall charts for contestants, coaches and spectators are exact duplicates of the master chart.

In all sports, the basic reason for keeping a scorebook or recording results is to establish a permanent record of what took place. Such a record should be easily read and interpreted by anyone who consults it an hour later, a month later, a year later.

Pairing officials across the USA have worked hard to develop standard notations for recording results and pairing. A unified system makes it easier for pairing officials from different areas to work together. In an emergency, one pairer can take over someone else's chart and continue without a problem. Wrestlers, coaches and spectators have become familiar with the standard symbols. And the permanent record can be interpreted for years to come. All pairing officials should learn and use standard procedures and symbols.

Notations on the pairing chart are made with a black pen, except for a few where red is indicated, such as the red dot. Copy machines often have trouble reading blue ink or pencil. (But you should use a pencil on the work sheet. That's the place to correct mistakes.)

Throughout the process of pairing and recording, write neatly and legibly... not for a "pretty" chart, but to reduce errors. An ornate script or style of lettering does not help bout sheet clerks spell names, nor help the announcer pronounce them.

PRINT IN CAPITAL LETTERS! Spell out the names of clubs and states. Keep things simple and easy to read.

Once the pairing official has finished pairing a round on his/her work sheet, and has checked it for accuracy, he/she receives the starting bout number from the chief pairing master. The bout numbers, the opponents' numbers and the red dots (indicating which wrestler wears red) are entered on the pairing chart. Bout sheets are prepared (red wrestlers on the left), checked for accuracy, and delivered to the chief pairing master. The data then is entered on the wall chart.

In competition between countries, a *programme* or "start sheet" must be prepared, using country codes, to indicate pairing for the session, singlet colors, order of bouts and assignment to specific mats. The chief mat official should receive copies of the *programme* at least one hour before competition begins, so he/she can assign neutral officials to each bout.

Start sheets are seldom used in the United States, because "on deck" calls speed the action by cutting down the time between bouts.

Two Bout Sheets

When two score sheets are used for each bout, (one for the judge and one for the mat chairman), as is the case of national and international events and most USA championships, the pairing official must compare the two sheets when they return, to be sure that they agree. If they differ in points, time or outcome, the chief mat official should be called to determine the correct result.

In the USA, the wrestler whose hand is raised to victory by the referee must sign the score sheet. Upon receiving the completed sheet, the pairing official looks first for the signature of the winning wrestler, to verify that the proper contestant has been credited with the victory.

The pairing official then checks the outcome (fall, technical superiority, decision, disqualification, etc.), adding the individual point for each wrestler to verify the scores. Individual scoring notations are official. A mistake in addition may be corrected by the chief pairing master.

Once the outcome has been verified the pairing official records the results in the designated box on his/her chart, using standard notations, and enters the appropriate number of classification points. In vertical pairing, the winner's points are entered on the pairing chart.

During preliminary rounds, instead of recording classification points for the loser, mark out his/her points box with a large "X" indicating a defeat. Another "X" will eliminate him. In the round-robin, where a defeat no longer leads directly to elimination, enter the classification points for both wrestlers.

STANDARD NOTATIONS (see pages 140-141)

When the bout ends in a fall, write the time of the fall in the “Time or Score” box for the winner. In the same box for the loser, write “LF” (lost fall).

When the bout ends in a decision, of any margin including a “technical fall” (actually a decision of technical superiority), write the score (3-2, 8-3) in the winner’s box and the reverse score (2-3, 3-8) in the loser’s box. When the bout is decided in overtime, circle the result in the time or score box for both the winner and the loser.

TABLE OF RECORDING SYMBOLS (All Periods Must Be Recorded)

Result (Time or Score Box)	Winner’s Box	Loser’s Box
Any fall	Time (1:46)	LF (lost fall)
Any decision (including technical “fall”).	Score (3-2, 8-3)	Reverse (2-3, 3-8)
Overtime decision.	Circled score	Circled reverse
Forfeit (no-show, failed to make weight).	WBF	FORF
Injury default.	WBI	INJ
Disqualification for misconduct		
Winner gets 5 positive points.	WBD	DQM
If ejected from the tournament.		DQM circled
Disqualification for fleeing, illegal holds		
Three cautions.	WBD	DQ
Double disqualification		DDQ

TABLE OF CLASSIFICATION POINTS

Result of the Bout.	Winner Earns	Loser Earns
Fall	5	0
Technical Superiority (6-point margin)		
Loser has technical points	4	1
Loser has no technical points	4	0
Decision (1-5 point margin)		
Loser has technical points	3	1
Loser has no technical points	3	0
Winner of 0-0 criteria or officials decision.	3	0
Injury Default	5	0
Forfeit	5	0
Disqualification for any reason	5	0
Double disqualification (both defeated)	0	0

A wrestler given a bye receives no positive points in that round.

“Misconduct” is a flagrant violation (brutality, fighting, swearing, etc.). The officials at the mat determine whether or not the wrestler is ejected from the tournament, and indicate their decision on the score sheet. Such a disqualification is subject to review by the protest committee, and must be reported immediately to the chief pairing master, who will hold the weight class and notify the chief mat official.

Use of the Red Pen

The red pen is used to call attention to symbols on the pairing chart which must not be overlooked. The items recorded in red are:

- Draw numbers on the pairing chart for wrestlers in Group A.
- A dot to designate which wrestler wears the red singlet.
- Elimination for misconduct, or when applicable, by forfeit.

- Tallies of classification points, added up as tie-breakers.
- Notations in the preliminary round squares of bouts carried forward to the round-robin:
 - Circle the bout number.
 - Slash the winner's positive points.
 - Blot out the area between the legs of the "X."
- Crescents marking advancement to the round-robin.
- The number of the place earned in the group or weight.

Eliminating a Contestant

During the preliminary rounds, leading to the round-robin (group) finals, a wrestler is eliminated when he suffers his/her second defeat. When the wrestler is eliminated:

- Mark out his/her draw number at the left of his/her name on the pairing chart.
- Mark out the "place" square at the far right edge of his/her line.
- Draw a heavy vertical bar immediately after his/her last series of notation, and
- Mark out his/her number on your work sheet, so you won't pair him/her for the next round.

118	SAM SAUNDERS	BYE																	
	MICHIGAN	--	2	16	14														
		0	LF	X	WBD	5	1-6	2-4	X										

It is not necessary to total each wrestler's positive points when he is eliminated. It is a waste of time. They are used so infrequently as tie-breakers that they should be totaled only when needed.

When a wrestler is disqualified from the tournament for misconduct, or is eliminated by a forfeit--and thus cannot earn a place--a red "E" in the "place" square on his/her line will keep you from considering him/her for a place accidentally.

If a wrestler fails to appear at a second or third weigh in, write "DNWI" (did not weigh in) after the vertical bar. If a wrestler fails to make weight, write DNMW.

RE-PAIRING A ROUND

When a contestant who has not been eliminated withdraws for any reason, the wrestler or coach should notify the chief pairing master, before the next round is paired, that the wrestler will be unable to continue. This doesn't always happen. So, when recording a loss by injury, summon the wrestler or his/her coach to find out if he/she will continue. If not, have one of them initial the chart and eliminate him/her.

Don't hesitate to announce the reason for a delay...to re-pair because of withdrawal, or because an error has been discovered.

Medical Alert System

To speed communication between the tournament medical staff and the pairing officials, USA Wrestling developed the "medical alert" system. When a wrestler loses by injury, or voluntarily seeks treatment by the medical staff, he/she comes under medical alert. The medical officer will complete one of three forms (stop...caution...go):

- A **red** form prohibits the wrestler from further competition in the tournament because the injury or illness is a threat to his/her well-being.

■ A **gold** form prohibits the wrestler from further competition until he again is examined by the medical officer. The gold form is attached to the wrestler's next bout sheet and it is the responsibility of the wrestler or his/her coach to replace it before he/she wrestles. If this is not done, he/she loses the bout by default.

■ A **green** form is medical permission to continue wrestling.

Except for the Olympic Division, where contestants are adults, the decision of the medical staff is final and is **not** subject to appeal. At the Olympic level, the contestant's wishes are considered by the medical staff, unless the injury is one where further competition could cause severe or permanent damage.

It is a USA Wrestling rule, for age groups below Olympic level, that a wrestler knocked unconscious by a blow to the head must be examined by a physician before he can continue. Such examination is not required at the Olympic level, but is recommended. If the two styles are conducted simultaneously or consecutively, an athlete receiving a red medical alert in one style must also be cleared to compete in the other style.

CLASSIFICATION (see pages 140-141)

The competition in a tournament consists of three distinct parts:

- The elimination rounds.
- The round-robin finals, determining placings in each group.
- The championship round, matching place winners from the two groups.

Elimination Rounds

The elimination or "preliminary" rounds, are all the rounds of a group (or single round-robin event) necessary to reduce the field until only three wrestlers are left with fewer than two defeats.

These three advance to the group finals, and the bouts among the three determine their places. Once a wrestler has reached the round-robin, a second loss does not eliminate him/her. He/she completes the round-robin and wrestles his/her counterpart from the other group.

Sometimes the elimination rounds leave only two wrestlers with fewer than two defeats. The bout between these two determines first and second places. There is no "forced" round-robin.

Wrestlers eliminated in the last previous round are considered for third place. If there are two wrestlers in consideration, the result of their bout is decisive. If they have not wrestled one another, the one with the most classification points in the event advances. If they have not met and have the same number of classification points, they must meet in a special bout. The wrestler with two defeats who advances in this manner does not wrestle in the round-robin, but automatically places third.

For places below third in the group, each wrestler is ranked by the round in which he was eliminated. If there are two wrestlers in consideration, the result of their bout is decisive. If they have not wrestled one another, the one with the most classification points in the event advances. If they have not met and have the same number of classification points, they must meet in a special bout. A wrestler who goes out in Round 6 with 12 points ranks ahead of a wrestler eliminated in Round 5, no matter how many points he/she has.

When two wrestlers who have not met are tied for any tangible award--such as a ribbon, medal, or advancement to the medal round--they must wrestle a special bout to break the tie. Otherwise, their placing can be determined by the series of tie-breakers listed on page 112.

When such a special bout is necessary, find unused squares on the chart, between the elimination round and the round-robin area, and indicate the bout

by marking black crescents on both sides of the special square. Tell the chief pairing master immediately that you have a special bout, so the wrestlers can be notified, and the special bout can be assigned a number and be scheduled on the flow chart.

Round-Robin Finals

In each group where three wrestlers remain with fewer than two defeats, they must meet each other. Their places are determined by the results of these three round-robin bouts. A wrestler who wins both of his/her round-robin bouts **must** be the winner. Classification points are only tie-breakers. If the round-robin wrestlers each win one, lose one, then the wrestler with the most classification points in the round-robin wins, second highest total places second, low man is third.

Two wrestlers do not meet a second time. Results of any bouts among the finalists during the elimination rounds are carried forward into the round-robin. This also applies when there are only two finalists and they have met in an earlier round.

Round-robins must be paired in the proper order of numbers, whether or not the wrestlers already have met. The order of group finals is not a matter of choice, but of formula.

It can cause trouble if you look for previous meetings before pairing all three bouts.

Here are the procedures for setting up a three-man round-robin:

On the work sheet, carry the three remaining wrestlers forward into the round-robin. The wrestler who received the most recent bye remains at the top of the list. Give the first bye in the round-robin to the wrestler now at the bottom, and continue as though setting up a new tournament just for those three wrestlers. Pair the opponents in order for all three rounds.

If you have followed proper recording practices, all but three wrestlers on your chart now have (1) their contestants' numbers marked out, (2) heavy vertical bars marking the end of their participation in the event, and (3) their "place" squares marked out.

Each of the three remaining wrestlers (group finalists) is now marked with a red crescent just in front of the first round-robin box, as shown in the example on pages 140-141. The crescents make them easier to find as you shuffle papers. Now record the pairing on your chart.

If one wrestler has two defeats and is an automatic third, mark a large "X" through his/her first round-robin box and large red "3" in his/her place square.

Now, and not until now, check for bouts between any two of the round-robin wrestlers in the elimination rounds. As you find them, carry forward the bout number and the classification points into the round-robin. Instead of carrying forward the time or score, place an arrow in the round-robin box.

Go back to their earlier meeting. Circle the bout number carried forward. Draw a slanted line through the positive points of the winner. For the loser, blot out the space between the legs of the "X" (where you would tally positive points for a defeat). These notations, in red keep you from counting classification points for the same bout twice.

NO	NAME	1	2	3	4	5	6	7	RR1	RR2	RR3	FINISH		
101	ADAM ANDERSON	3	5	7	11				19	BYE				
	MINNESOTA	D 12-7 5-1	4-5 2-3	X D 6-2 3-1	3 TF 8-0 8-0	4			D 8-5 8-3	3	--	0	5 =>	1

It may be that none of the contestants have met. It also may be that one, two or even all three of the round-robin bouts will be carried forward. These results are valid.

A wrestler who defeats both opponents is the winner. If there's a three-way tie at one win, one loss, we turn to classification points. The only classification points of concern are those earned in the round-robin. These points determine the top three places in the pool.

You return to positive points in the elimination rounds only if there also is a tie among the contestants on points in the round-robin, or to determine places below third.

Final Classification

Each finalist has two opportunities to win a bout and to earn positive points in the round-robin (the other square will contain a bye and a zero).

If there is a three-way tie at one win, one loss, the points earned in these two bouts determine final placing. Remember, the loser of a bout can earn a point but two victories are worth more than one victory, whatever the point totals.

In case of a two-way tie for any position, the result of their bout decides it, even if that bout was carried forward from an early round. If both wrestlers were disqualified when they met each other, consult the list of criteria which follows.

If all three wrestlers earn the same total classification points in the round-robin (usually 5 or 4), the winner is the contestant with the most points for the whole tournament. In such a situation, a bye or a carry-over may be a liability, because there are no points for a bye, and points for a carry-over already have been counted in the round-robin.

Here are the tie-breakers, in order:

1. The most classification points for the entire competition.
2. The most victories.
3. The most victories by "Fall."
4. The most victories by superiority (4 classification points).
5. The most periods won by superiority.
6. The most technical points scored in all the competition.
7. The least number of technical points given up in all the competition.
8. The least time of the falls (cumulative).
9. The least time of the victories by technical superiority (cumulative).

A 48-year-old rule is used as a last-gasp tie-breaker. If none of the criteria has broken the tie, the wrestlers are weighed, and the lightest wrestler wins. Presumably, he/she has made up a slight difference in weight with slightly more ability.

If you see the possibility of a tie coming up, start looking at the tie-breakers. Find out how far down the list you may have to go to determine the place winners. If it looks as though it could go all the way to a weigh-in, arrange to have each of the wrestlers involved taken directly to the scales as soon as his/her last bout is over--to keep one from cutting weight while his/her opponent is wrestling.

In adding up a wrestler's classification points, remember that even when he/she was defeated he/she could have earned a point. To be sure you tally all of his/her classification points, write a zero or one between the legs of the "X" which you used to show a loss.

Important Note

In using tie-breakers, the first one which has any effect may settle all three places. For example, "most victories" may tally 5-4-3 and determine first, second and third places.

Sometimes the first effective tie-breaker places one wrestler first or third, but leaves the other two tied. Any two-way tie is determined by the winner of their bout. For example, “most classification points” may tally 16-15-15, placing one wrestler first, or 16-16-15, placing one wrestler third. Don’t look for any more tie-breakers, the tie between the other two wrestlers is determined by their head-to-head competition -- the winner of their bout places higher than the loser.

In a single round-robin tournament, the competition is now over, you can award the medals and everyone can go home. With the pool system, you are now ready for the medal round and finals.

Championship Round

In each group, you now have determined the first three places, either by a round-robin among three survivors or by a single bout among two survivors and direct placing of a third contestant. Place winners from the two groups are matched in “direct” finals:

- 3 vs. 3, for fifth and sixth places.
- 2 vs. 2, for third and fourth places.
- 1 vs. 1, for first and second places.

And, of course, 4 vs. 4, for seventh and eighth. The wrestler from Group A (the “red” pool) wears a red singlet in the finals.

Total Elimination

A wrestler forced out of the event by injury or other medical reason can place. If he/she qualified for the finals and had medical verification, he/she is awarded second, fourth, sixth place, etc.

A wrestler who attends a second or third weigh-in, but is too heavy, no longer is given the break he/she received under rules of past years. He/she is subject to total elimination, is disqualified from the event for misconduct, or fails to appear at the weigh-in. The wrestler at fault becomes a “non-person” who can’t place, can’t score team points and can’t use the event as any form of qualifier. See page 69 for ***USAW Modification*** regarding forfeits.

During the Group Finals

If total elimination of a wrestler occurs before the group finals are complete, the pool becomes a two person event and the bout between those two determines the winner. For tournaments where eight places are awarded, such as the Cadet and Junior National Championships, the fourth place wrestler in that pool advances to the finals as the third entry from the pool and wrestles for fifth place in the tournament.

During the Championship Round

If total elimination occurs after the group finals, and before or during the championship round, there is a gap in the standings. After the finals, place winners are advanced in order to fill the vacancy. (If the silver medalist is gone, bronze becomes silver, fourth becomes third, etc.)

This procedure moves the gap to the bottom of the list. No other wrestler is moved in from a lower ranking to fill that gap.

Group A Elimination Rounds

There are five bouts in the first round. Positive points are recorded for the winners, an “X” for each loser.

Pairing the second round results in a “back force” when 11-15 leaves a rematch of 17-19. You are forced to back up one notch and re-pair 11-17, which solves the problem.

In the second round, No. 17 is disqualified for misconduct. The “E” signifies his/her ejection from the tournament...he/she cannot place.

In the third round, No. 5 defeats No. 11 by a score of 8-7, 3-2. In the fourth round, No. 11 loses by technical superiority and fails to score in the bout. Had he/she scored, he/she would have earned a positive point and placed fourth. As it is, he/she is forced into a special bout, and loses.

Group A Finals

After four rounds, three contestants remain with fewer than two defeats. A full round-robin is established, giving No. 5 the first bye because he/she is at the bottom of the list headed by No. 19.

Bout 381 then is carried forward from the second round. It is important to mark out positive points for both wrestlers in the second round, as shown, so they won't be counted twice.

Including the bout carried forward, each wrestler has defeated one opponent by a decision, each scoring 4 positive points in the round-robin. The first tie-breaker is total positive points for the entire competition. No. 19 has 15 points and places first, No. 1 has 14 points and is second, and No. 5 has 13 points and is third.

Because this tournament awards eight places and advances four from each group, fourth round losers No. 11 and No. 13 are compared. Each has 9 positive points, and they have not met, so a special bout is scheduled (at the same time as the first bout of the round-robin). No. 13 wins and earns fourth place.

Group B Elimination Rounds

With an odd number of wrestlers, No. 18 receives a bye in the first round and advances with no positive point. The bye goes to No. 16 in the second round.

In the second round, No. 12 is a “no show” and is eliminated, as the forfeit is his second loss. In the third round, No. 2 wins by injury. No. 16 is disqualified with three cautions, but it's only his/her first defeat, so he/she may continue.

Group B Finals

After five rounds, only two wrestlers remain with fewer than two defeats. They are paired in a single bout for first and second.

No. 14 and No. 16 both went out in the fifth round. Even though No. 14 has more positive points (9-7), No. 16 places third and No. 14 is fourth because of their head-to-head match result (No. 16 defeated No. 14).

Medal Rounds

No. 413, fourth in Group A, is paired against No. 416, fourth in Group B, for seventh and eighth places. Bouts for seventh, fifth and third are wrestled at the same time, followed by the championships.

PAIRING OFFICIAL'S WORK SHEET

Elimination Rounds

Round 1	Round 2	Round 3	Round 4	Round 5	Round 6	Round 7	Round 8
401 3 } 161	1 3 } 381	1 5 } 628	1 5 } 718		SPECIAL		
5 7 } 162	5 7 } 382	7 11 } 629	11 13 } 719		11 13 } 778		
9 11 } 163	9 11 } 383	13 19 } 630	19 BYE				
13 15 } 164	13 15 } 384						
17 19 } 165	17 19 } 385						

RR 1	RR 2	RR 3
19 1 } 778	5 19 } 789	1 5 → R2
5	Bye	1
		Bye
		19
		Bye
Weight	98	Division
		FS

Round 1	Round 2	Round 3	Round 4	Round 5	Round 6	Round 7	Round 8
402 4 } 166	18 2 } 386	16 18 } 631	14 16 } 720	10 14 } 779			
6 8 } 167	4 6 } 387	2 6 } 632	18 2 } 721	16 2 } 780			
10 12 } 168	8 10 } 388	8 10 } 633	10 BYE				
14 16 } 169	12 14 } 389	14 BYE					
18 BYE	16 BYE						

RR 1	RR 2	RR 3
10 2 } 790		
-	Bye	Bye
		Bye
Weight	98	Division
		FS

Tournament Operations

Vertical Pairing System

THE BIG PICTURE

There is much more to a wrestling tournament than pairing the contestants, calling them to the mat, officiating their bouts and recording the results. The whole package comes together as the science (or art) of tournament operations.

There are three key roles in tournament operations. The chief mat official, chief pairing master and the event director are full partners in the success of the event. Each directs an essential corps of volunteers — referees, pairing officials and floor workers such as timers, runners and arena setup personnel. These leaders (and their designated assistants) work together to start each session on time, and remain in constant communication throughout the event to assure smooth, orderly procedures.

For regional and national events, USA Wrestling assigns an event coordinator to supervise all aspects of the tournament. This individual has the responsibility and the authority to make decisions on any items of controversy, such as a change in the schedule, and must be consulted and kept informed throughout the event.

The tournament operations team also includes the announcers, clerks, typists, copy machine operators, medical staff, weighmasters, media coordinators, cleanup crews, registration personnel, concessionaires and many others.

As a pairing official gains experience and expertise, he/she advances toward the rank of pairing master. A chief pairing master is assigned to direct each major tournament and must be able to plan the entire schedule and carry it out in consultation with the chief mat official, event director and event coordinator.

- Given a reasonable estimate of the total entry, and a fixed number of available mats, he/she can determine how many hours, how many sessions, will be needed for a proper schedule.
- Given a reasonable estimate of the total entry, and a fixed time schedule, he/she can determine how many mats will be needed for a proper schedule.

This case study is intended to provide guidelines on organization of the entire tournament, from the first weigh-in and preliminary clinics through the final session and the presentation of awards.

Although this guide refers to the pairing official and “his/her” role and “his/her” responsibilities, the fact is, more women than men are certified as pairing officials and pairing masters nationwide. The world of wrestling is by no means exclusively a man’s world.

TOURNAMENT PLANNING FORMULAS

USA Wrestling formulas are based on years of research and serve as planning guidelines.

By applying these formulas, the pairing master can determine in close approximation the total number of bouts, the number of rounds per weight class, the number of mats needed, and the hours and sessions required.

Number of Bouts

Fewer than 100 entries	Multiply by 1.6
100 to 150 entries.....	Multiply by 1.7
151 to 250 entries	Multiply by 1.8
251 to 350 entries.....	Multiply by 1.85
351 to 500 entries.....	Multiply by 1.9
501 to 800 entries.....	Multiply by 1.95
More than 800 entries	Multiply by 2.0

In tournaments with a large number of weight classes, each age category should be calculated as a separate tournament.

Number of Rounds

Statistics compiled over several years of events in the international styles show that approximately one-third of the remaining contestants are eliminated in each round, starting with the second round. A substantially higher or lower percentage in one round will average out in subsequent rounds. Each group will follow these trends:

5 to 8 contestants	4 or 5 rounds
9 to 12 contestants.....	5 or 6 rounds
13 to 16 contestants.....	6 or 7 rounds
17 to 24 contestants.....	7 or 8 rounds
25 to 32 contestants.....	8 or 9 rounds
33 to 48 contestants.....	9 or 10 rounds
49 to 64 contestants	10 or 11 rounds
65 contestants or more.....	11 or 12 rounds

These are the rounds necessary to complete one group (pool), or a single round-robin event. Add one round for the finals.

Bouts Per Hour

USA Wrestling Modification

In Kids competition, including the national regionals, bouts are:

Schoolboy/girl:	3 - Two 2-minute periods with 30 seconds rest.
Novice:	3 - Two 2-minute periods with 30 seconds rest.
Intermediate:	3 - Two 2-minute periods with 30 seconds rest.

Although research under this rule continues, when all contestants are from the same country and speak the same language, three period Senior level Greco-Roman bouts should average about six (6) per hour per mat over the entire course of the event. On the other hand, Senior Freestyle bouts should average about eight (8) bouts per hour per mat. If the wrestlers speak different languages, and/or they are introduced with ceremony, additional time must be allowed.

Junior Greco-Roman bouts should average about eight (8) per hour per mat. Junior Freestyle bouts should average about ten (10) per hour per mat.

Cadet bouts should run about ten (10) per hour per mat for both styles. Even with a 30-second rest period, Kids bouts should run at least 10 per hour.

Bouts often go more rapidly in the early rounds and slow as the more accomplished wrestlers meet in the later rounds. Calculations are based upon use of "on-deck" calls, sending the next two wrestlers to warm up near the mat to which they have been called.

PLANNING THE SCHEDULE

There are two approaches to the preliminary schedule. If mat space is no problem, and you have plenty of qualified officials and other personnel, then decide what hours you want to wrestle and determine the number of mats needed. On the other hand, if your space and/or personnel are limited, reverse the calculations to determine how many hours are required.

For example, say you expect 240 entries. Applying a factor of 1.8, you can expect 432 bouts. If you are using the pool system, you can figure on 30 of these for six-place finals (20 for four places, 40 for eight places), leaving *approximately* 402 in the preliminary rounds. A single round-robin event also figures about 30 bouts in the final session, again leaving 402 in the preliminaries.

Even if you don't plan a separate session for the finals, your tournament slows down when you reach the round-robin. Fewer mats are used and bouts are spaced out to allow for mandatory rest periods. You must allow time for finals and awards in your planning.

In pre-tournament calculations, expect the 3-period bout of 2 minutes for each period to average eight (8) per mat per hour. They may run 8.5 per hour, but it's better to be surprised by how well the tournament is running than by how far it is behind schedule. Divide 402 by 8 and you get 50.25 (call it 50) mat-hours of wrestling.

If you were to run this tournament all on one mat, the preliminary rounds would require 50 hours; on two mats, about 25 hours; on four mats, about 12.5 hours.

How many hours?

Suppose your arena space is limited to five mats. Dividing 50 by 5, you determine that your elimination rounds must total about ten (10) hours, not including the finals. You must draw your time schedule accordingly.

How many mats?

This is the other side of the coin. Suppose you are locked into seven hours for the preliminaries — 9 to noon Saturday morning and 1 to 5 Saturday afternoon, with the finals Saturday night. To complete 50 mat-hours of preliminaries in 7 hours, you will need at least 8 mats (50 divided by 7 equals 7.14). However, you will not be able to keep 7 mats open for 7 hours because of mandatory rest periods. Use the extra mat at the start to speed up the early rounds and give yourself more flexibility later. Rest periods between bouts cause no problems in the early rounds.

As the tournament progresses, and the rounds get shorter, it may not be possible to keep all the mats in use because of mandatory rest periods. If an extra mat is available at the start, use it to speed up the early rounds and give yourself more flexibility later. Rest periods between bouts cause no problems in the early rounds.

Before each session, discuss your plans with the chief mat official, event director and event coordinator. When you close mats, they may wish to reassign personnel to other mats. And it may be possible to alternate bouts between mats to keep both officiating crews active. When closing a mat, try to give 15 minutes notice.

A closed mat is difficult to reopen. When you look around, those officials will be gone, the table workers will be gone, maybe even the mat itself will be gone. If you think you might need it later, don't close it yet ... put it on standby and ask the personnel to stick around.

Always start on time and use the “first open mat” principle. As soon as a bout ends, another should be ready. On-deck wrestlers should be instructed by the announcer to report either to a specific mat while one bout is in progress, or should be alerted to warm up for the first open mat. No more than two bouts, one in progress and one on-deck, should be assigned to a specific mat at one time. A long delay on that mat, such as for injury, thus holds up only one bout behind it and not a whole string of bouts assigned in advance.

If a severe injury closes down a mat for a long time, take the on-deck bout away from that mat and assign it somewhere else. There are two reasons. First, the weight class will not be subject to a long delay. Second, and more important, young athletes won’t have to watch (and worry about) elaborate medical procedures.

If you plan a separate session for the round-robin bouts, you are ready when each weight class or group has been reduced to either three or four contestants. If five or more remain, they should wrestle another elimination round. When four remain, one of the next two bouts will be carried forward into the round-robin (although you won’t know which one until both are over), or two wrestlers will be eliminated and two left for the finals.

Finals and Awards

Time must be allotted to present the championship round with appropriate ceremony. Under the pool system, the medal round (bouts for third, fifth, etc.) may be held first, followed by championship matches and awards. The awards should be presented with ceremony and with dignity, at a pause in the competition or afterward.

TABLE OF MATS AND HOURS

The following tables are presented as a guide to the number of mats and the number of hours needed to conduct tournaments in the international styles. At 3 to 4 hours per session, it is possible to squeeze 10 to 11 hours of wrestling into one day, but it is far better to adopt a “loose” schedule.

Plan for more time than you think you will need, and more mats than you think you will need. Don’t send everyone home totally exhausted and certain never to come back. A “loose” schedule allows time for emergencies, for unforeseen occurrences, and helps make the event more fun for everyone.

TABLE A
6-Minute Bouts with 30 second rest, 8 per Hour per Mat

Total Entry	Total Bouts	----- Number of Hours Needed on -----				
		1 Mat	4 Mats	6 Mats	8 Mats	10 Mats
200	360	45	11	7.5	5.6	5
250	450	56	14	9.3	7	6
300	555	69	17	11.5	8.6	7
350	648	81	20	13.5	10.1	8.1
400	760	95	23	15.8	11.8	9.5
450	855	106	26	17.5	13.3	10.7
500	950	118	29	19.7	14.8	11.9
550	1073	134	33	22.3	16.7	13.4
600	1170	146	36	24.3	18.2	14.6
650	1268	158	39	26.4	19.8	15.9
700	1365	170	42	28.4	21.3	17
750	1463	182	45	30.4	22.8	18.2
800	1560	195	48	32.5	24.3	19.5
900	1800	225	64.56	37.5	28.1	22.5
1000	2001	250	62	41.6	31.2	25

THE TEAM CONCEPT

The tournament operations team makes up a vital part of any wrestling event. Its sole responsibility is smooth, efficient conduct of the event. Members of the team include:

- Event coordinator, staff representative of the national office.
- Event director, responsible for local personnel and for all arrangements for the facility.
- Chief mat official, in charge of referee-judges.
- Chief pairing master, in charge of the “head table.”
- Pairing teams, one or more, each with two members. Depending on the personnel available and their skills, each team may be assigned two or more weight classes or groups. Tag their chairs on the back, so the chief can find any weight class at a glance.
- Clerks, for wall charts, plus a chief clerk for large tournaments.
- Announcer or announcers.
- Announcer’s assistant or assistants, to coordinate the flow of bout sheets.
- Floor manager, who has immediate access to the arena superintendent, electrician, etc.
- Promotions and media coordinator.
- Medical liaison.
- Weighmaster and drawmaster, and their assistants.
- Typists and copy machine operators.
- Additional personnel as needed.

The objective of the team concept is to eliminate human error through specific assignment of responsibilities, reduction of fatigue, relief of high-pressure situations, and a constant system of checking and double-checking and communicating with each other.

It does not matter who makes a mistake, or who catches a mistake, as long as errors are corrected *before* they reach the mats and have an adverse effect on the competition. It serves no purpose to “keep score” and determine that “I made only two mistakes today, while my partner made five.” The only correct score is “*We made no mistakes today.*”

Always remember that the chief referee, tournament director, floor manager and the chief medical officer are part of the total team, whose “captain” is the event coordinator. Each of these individuals should have a place at the head table, or in another working area.

THE TEAM IN ACTION

Event Coordinator

- Supervises and coordinates the work of the volunteers, and ensures that the over-all image and conduct of the event maintain the standards of USA Wrestling.

Event Director

- Recruits and directs the local corps of volunteers, obtains and prepares the facility, sets up and oversees registration, ensures that the contract with USA Wrestling is fulfilled.

Chief Mat Official

- Conducts or assigns clinics and exams for referee-judges and supervises their work throughout the event.

Weighmaster

- Directs the weigh-in staff, coordinating with the chief medical officer, and certifies the proper weight for each wrestler. The weighmaster will need two assistants at each scale.

Although the rules say the weigh-in and drawing of lots must be carried out in public, the term “public” doesn’t mean just anyone. Credentials should be checked at the door and admission limited to athletes, coaches, club and state representatives, tournament staff and others with legitimate reasons to be present. The Weighmaster also coordinates the collection of weigh-in cards from all wrestlers. Male contestants must be weighed with their singlet on and female contestants must weighed with a leotard on. No weight allowance is given.

Chief Pairing Master

- Conducts or assigns clinics and exams for pairing officials.
- Supervises preparation of the original pairing charts, wall charts and bout sheets.
- Maintains the flow chart throughout the tournament to determine the order of weights, the number of bouts within each weight, the number of mats in use at any time, the number of rounds per session.
- Plans the final session and awards presentations.
- Acts to correct errors.
- Supervises the entire operation of pairing, announcements and protests.

All questions should be directed first to the chief pairing master or his/her assistant, who then determines the answer from the proper person. This practice eliminates unnecessary interruptions, which cause errors.

Pairing Teams

Two pairing officials per team. Each works independently to record, advance, eliminate and pair his/her assigned weight classes or groups, always checking his/her findings against those of his/her teammate.

In a large tournament, it is recommended that pairing teams be assigned to alternate weight classes or groups, or to different age groups. While Team A is working carefully on the 60kg weight class, it need not be concerned with mounting paperwork at 66 kgs...that will be Team B’s responsibility. Team A will have the time necessary to cross-check its 60 kgs records completely, before taking on the 74 kg weight class. The advantages of this alternating system are clear:

- Adequate time for checking reduces errors.
- Easing of mental pressures reduces errors.
- Elimination of fatigue from long-sustained effort reduces errors.
- “Break” time allows personnel to watch some of the competition.
- More pairing personnel become directly involved in the operation of the tournament, a key factor in the development of new talent.

Face another fact — these are volunteer officials, who are working the tournament because they enjoy it, because they feel a commitment to the sport of wrestling, and often because they are personally involved, with sons/daughters wrestling and spouses coaching or refereeing. Unless these volunteers realize some fun from their efforts, they may not be around the next time we need them.

Clerks

Receiving one copy of a completed and cross-checked pairing chart, the clerks immediately prepare bout sheets for the next round and bring the wall charts up to date. Prompt updating of the wall charts is another safeguard against error, because wrestlers and coaches have the opportunity to discover and question incorrect entries. The new bout sheets are rechecked against the pairing chart before being delivered to the chief pairing master.

In a large tournament where there is a lot of paperwork, a chief clerk should be appointed to direct the production of bout sheets and wall charts, and to record each completed step on a tally sheet, so that no weight class or group is overlooked. To ensure this, the clerk shall organize completed bout sheets of each weight class.

Announcer

Calls the wrestlers to the mat, either for immediate competition or for on-deck status (at the discretion of the chief pairing master.) Makes all other calls and announcements necessary to the competition, and conducts special ceremonies and the awards presentations. Large tournaments with 10 or more mats in use often require that these duties be divided among two announcers, particularly if individual results are given.

Announcer's Assistant

This individual receives the numbered bout sheets, in order, from the chief pairing master. The announcer's assistant assigns mat numbers for the first series of bouts on the mats in use, and passes the bout sheets to the announcer. If an on-deck procedure is in use, he/she assigns the second series to the mats and delivers those sheets to the announcer. When the first result is returned from any mat, he/she assigns the next bout (or on-deck bout) to that same mat, and proceeds in this pattern throughout the session.

Using a bout sheet tracking form, an announcer's assistant records the number of the mat where each bout is sent, so the head table team can find any score sheet at any time. When a wrestler misses his/her call to the mat, bout sheet tracking helps answer questions and keeps the tournament moving. It also helps when the pairing master must recall a score sheet for corrections or adjustments.

An announcer's assistant also collects incoming bout sheets, marking off returned bouts. In the late stages of a tournament, the assistant will check each incoming bout sheet for "time bout ended." The chief pairing master needs this information to assure each contestant 15 minutes rest.

In large tournaments, the responsibilities of the announcer's assistants should be divided among two or more individuals.

Floor Manager

He/she is in charge of obtaining timers, scoreboard operators and runners for each mat, each session, and their replacements when needed. He/she also

is responsible for all equipment — backup timing systems if a scoreboard fails, pencils, clipboards, scoring paddles and blocks, etc., delivering them to the mats before each session, and collecting them at the close of each session. Moving, taping and cleaning of mats, along with crowd control, also fall within his/her responsibilities.

Medical Liaison

A large tournament also will require a medical liaison clerk, to communicate with the medical staff and coordinate the flow of medical alert forms. In smaller tournaments, medical concerns should be directed to the chief pairing master.

Media Coordinator

At least one person should be assigned to give the news media all the information it could possibly want before the tournament, during the tournament, and after the tournament. This person should be able to read a pairing chart and, if necessary, to interpret it for a reporter. He/she should know enough about the event and the contestants to point out athletes and match-ups of special interest, to arrange interviews, and to provide highlights that can add to the bare results. This person should not be responsible for any other duties...he/she should always be available to the news media. He/she also may be assigned to call or wire results to certain news outlets.

Summary

At the pre-tournament setup session, the chief pairing master assigns pairing teams to pair the first round, while clerks prepare wall charts and bout sheets.

During the competition, bout sheets go from the clerks to the chief clerk...to the chief pairing master...to the announcer's assistant...to the announcer...to the runners and the mats. They return to the announcer's assistant (results may be announced, if you wish)...to the chief pairing master...then to the appropriate pairing teams.

Results and eliminations are recorded, and cross-checked. The next round is paired, and cross-checked. One pairing chart goes to clerks who update the wall charts, the other copy to clerks who prepare bout sheets for the next round. The pairing chart can be duplicated on a copy machine for the media coordinator. One copy of the pairing chart, and the accumulated bout sheets, must remain at the head table at all times.

New bout sheets are cross-checked against the pairing chart, then are delivered by the chief pairing master to the announcer's assistant, who places them on the bottom of his/her stack, maintaining the order of bout numbers.

Bout numbers are important, and should be announced when each bout is called by the announcer. They help wrestlers and coaches anticipate and prepare properly for their next match. And they are the foundation upon which the flow chart is constructed.

CHIEF PAIRING MASTER

The duties of the chief pairing master start weeks before the event, when he/she obtains an estimated entry total and uses formulas to plan the time schedule and the number of mats needed. These figures are subject to minor adjustment when the official entry becomes available, but you must live with what you put down in writing. A "loose" schedule, allowing plenty of time, is easy to adjust. A "tight" schedule, with no margin for error, may be wrecked by a sudden surge of entries.

After organizing the tournament operations team and assigning specific duties, the chief pairing master then directs his/her personnel through the drawing of lots, pairing and preparation of wall charts and bout sheets. Each pairing master is also a teacher, and the pre-tournament pairing clinic is the ideal place to discuss standard procedures and unusual situations, and to answer the questions from pairing officials.

Throughout the competition, the chief pairing master must control the pace of the tournament, working with the chief mat official and the event director to meet broad guidelines established in consultation with the event coordinator.

The chief pairing master's most important tool is the flow chart. It will help him/her decide:

- How many mats are to be used at any given time.
- What weight class will open each session, and the order in which the others will follow.
- How many bouts should be completed in each session.
- How many rounds each weight class should wrestle in a given session.
- How to deal with protests.
- How to deal with errors.
- How to establish the order of weights for a final round-robin session.
- How to provide the media with results during and after competition.
- How to provide the weighmaster with the names of wrestlers who are to appear at a second weigh-in.
- How to provide the announcer the necessary information for presentation of awards.
- When to release each weight class until the next session.
- When to release each weight class for weigh-ins.

THE FLOW CHART

If all weights had the same number of entries, there would be few problems. The 92.5 pounders would start the tournament, and all weights would follow in order. But wrestlers don't grow that way. Middle weights will be packed and lighter and heavier weights will have fewer numbers. Weights with more entries wrestle more rounds, as shown in the planning formulas, so start with those weights.

On the flow chart, list the weight classes and groups in order, and the number of entries in each. This presents a picture of the entire field. Find a "break point" at the start of the larger classes, mark it for the start of the tournament and assign bout No. 1. Continue listing first round bout numbers.

As each group completes a round, enter the number of contestants remaining in the group. If that weight class is going to wrestle again in the same session, bout numbers can be assigned. If the weight class is through for the session, don't assign the next set of bout numbers until you have analyzed the starting point and the order of bouts for the next session.

Once a group has reached the round-robin, there will be three contestants, but not necessarily three bouts. Using small marks after the 3, show yourself how many rounds remain (3^{III} or 3^{II} or 3^I). Use a small "s" to show the need for a special tie-breaker bout.

The flow chart enables the pairing master to follow the pace of the tournament, giving him the information he/she needs to make decisions on the number of mats in use, whether to release a weight class for the rest of the

session or hold it for another round, etc.

For the wrestlers' benefit, the weights should be scheduled in the normal upward order. If competition starts at 119 pounds, proceed upward through 220, then pick up 92.5, 101 and 110 pounds. A 152-pound wrestler is used to following the 138.5-pounders to the mat, and will have a reasonable idea when to warm up for his/her bout just by looking at the size of the contestants who are wrestling. Because this practice has been widespread for years, small wrestlers now are used to following heavyweights to the mat.

The order of weights should be announced before each session, and a copy should be posted at the wall charts. It also helps to post a copy in front of the announcer ... wrestlers and coaches come there to ask, and find that their question has been answered. If possible, the posted order of weights should indicate how many times each weight class will wrestle during a session. But if you post "no more than twice," you're stuck with no more than twice. When in doubt, leave question marks on the posted list.

In later rounds, a weight class or two often refuses to "break" and you have a round you weren't counting on. Until the end of the session, you may run these weights out of order — even through group finals — as long as you let wrestlers, coaches and spectators know what's going on.

ORDER OF WEIGHTS			
<u>Friday Afternoon</u>			
119	I	II	---
127.5	I	II	---
138.5	I	II	---
152		STOP	
167.5		---	
187		---	
220		---	
92.5		---	
101		---	
110		---	

ORDER OF WEIGHTS			
<u>Friday Night</u>			
110	II	III	---
119	III	IV	---
127.5	III	IV	---
138.5	III	IV	---
152	II	III	---
167.5	II	III	---
187	II	STOP	
220	II	---	
92.5	II	---	
101	II	---	

If a weight class or group is so small, or so far along, that it need not wrestle in any given round, you may skip over it in its turn, writing "skip" on the flow chart and on the order of weights.

If you are certain that a weight class will not wrestle again in a specific session, release that weight until the scheduled starting time of the next session. Only the announcer, on instructions from the chief pairing master, can release a weight class from further competition. No other member of the tournament operations team ever should tell any contestant that he/she is free to leave the arena.

The sample flow chart on page 127 is for a tournament of 240 wrestlers in 10 weight classes (20 groups), going to finals for six places. From the tournament planning formulas (page 113), we can expect approximately 432 bouts in the tournament ($240 \times 1.8 = 432$). With finals for first, third and fifth places, we subtract 30 finals and expect some 402 bouts in the preliminary rounds.

Have five mats available and four sessions, with published starting times of 1 p.m. and 7 p.m. on Friday and Saturday.

Friday afternoon

Try to wrap up the first session around 4:30 p.m. Starting on time, you can count on completing 175 bouts comfortably (5 mats at 10 per hour for 3.5 hours = 175).

Of the 20 groups, those at 119, 127.5 and 138.5 pounds are significantly larger than the others and will wrestle more rounds in the tournament. Run an extra round this session by starting at 119 pounds and wrestling the six largest groups twice each. It would not be “wrong” to start at 110 pounds, but the main concern right now is getting through the 138.5-pound class a second time.

The 92.5-pounders already are at the round-robin level and can be released until the second session. However, each weight class should wrestle at least once every session, if possible. The 92.5-pounders came to wrestle, and perhaps people came to watch them. It is advisable to work them in early in each session, then release them until the next session.

On the sample flow chart, note that a wrestler has been moved from 152 pounds to 167.5 pounds after the first round bout numbers had been assigned. Someone made a mistake, but it’s easy to handle. There will be only six bouts instead of seven in 152 Group B. So there is “no bout No. 70” and you mark that on the flow chart. There’s an extra bout in 167.5 Group B. Number it 81-A, and run it between 81 and 82. Let the announcer’s assistant know of the changes.

If your tournament starts on time and runs on schedule, after one hour you should have completed 50 bouts and be wrestling at 138.5 pounds. After the second hour, you should have finished 100 bouts and be completing 101 pounds. Compare the actual numbers with your projection and you’ll know whether you are on time, ahead of, or behind schedule. If there is an injury, one mat may be closed for a period of time, thus your projection may be affected. In calculating your position, remember there are bouts on the mats not yet complete and “on-decks” not yet begun.

Wrestle 171 bouts in the first session (once you start the round for a weight class, you have to finish it.) Tournaments usually move well in the early rounds, so you shouldn’t have much trouble with 171 bouts in the first session. You should always try to finish the session on time as scheduled. It is much better to finish ten minutes early, rather than fifteen minutes late. If there is not enough time allotted for completion of the tournament as scheduled, the chief pairer should meet with the tournament committee to decide the hours to be wrestled.

If you really run ahead of schedule, it’s possible to get the 152-pounders on the mat again this session. List them as questionable for a second round. In an hour or two, you should know, and be able to schedule them or release them. Decisions about whether to hold or release a weight class must be applied to the entire weight class, not just to one pool. The wrestlers in both groups should have the same amount of time to prepare for the next session, or the next weigh-in.

But in this example, assume that 171 bouts fill the first session. Tonight, start the second session with No. 172.

FRIDAY AFTERNOON					FRIDAY NIGHT				
Weights	Start	Bout Nos.	Rem.	Bout Nos.	Rem.	Bout Nos.	Rem.	Bout Nos.	Rem.
92.5	4	92-93			4	256-257	2		2
B	3	94			3	258	3		3
101	9	95-98			9	259-262	6		6
B	8	99-102			8	263-266	6		6
110	14	102-109			14	172-178	10	267-271	7
B	13	110-115			13	179-184	9	272-275	6
119	19	1-9	19	116-124	13	185-190	9	276-279	6
B	19	10-18	18	125-133	12	191-196	8	280-283	6
127.5	21	19-28	21	134-143	15	197-203	10	284-288	7
B	20	29-38	20	144-153	14	204-210	9	289-292	6
138.5	18	39-47	18	154-162	13	211-216	9	293-296	6
B	18	48-56	18	163-171	12	217-222	8	297-300	5
152	14	57-63	12		12	223-228	8	301-304	6
B	14	64-69	13		13	229-234	9	305-308	6
167.5	12	70-75			12	235-240	8	309-312	6
B	12	76-81			12	241-245	7	313-315	5
187	5	82-83			5	246-247	4		4
B	5	84-85			5	248-249	3		3
220	7	86-88			7	250-252	5		5
B	6	89-91			6	253-255	4		4
Total	240								

Friday night

The second session has three hours scheduled, so you can expect to complete about 150 bouts (5 mats x 10 per x 3 hours = 150). Look at the number of contestants remaining after the first session. The six largest groups have been reduced to the same number of wrestlers as the 110-pounders, so 110 is the place to start the second session.

Try to get through 152 twice, and maybe even 167.5. Watch the flow chart as the evening session progresses.

After one hour of tonight's second session, you should have completed 50 more bouts (total 221) and be finishing 138.5 pounds or be wrestling at 152 pounds. After two hours you should have finished another 50 (total 271), completed the first round and be into the second round of this session at 110.

We mentioned weights that "refuse to break." As the session winds down, you can see trouble in that "9" in 152 Group B. But fortunately you have enough time to run the 152-pounders one more time tonight, and also 167.5 for a second time. After the completion of those two weight classes, you will have completed a total of 316 bouts which will allow you to finish about right on schedule. It also prevents trouble in the next session as "9" might be

translated into five rounds the next day—a problem you should always try to avoid, if possible.

In the early rounds, rest between bouts is never a problem. Bout Nos. 203 and 284 at 127.5 pounds are a little more than an hour and a half apart. Later, as the tournament works down to the group finals, and weight classes return to the mat more frequently, you must keep a firm grasp on the situation. Close a mat, or two, or you'll run into rest-time problems and empty mats late in the session.

No one buys a ticket to watch empty mats. As long as you control the pace of the tournament, there should always be at least one bout in front of the spectators.

Saturday afternoon

Looking at your flow chart, your numbers look relatively good; however, you have two "7's" which could indicate an extra round in these groups. Sure enough, they need an extra round to complete the group finals ... see bout Nos. 409 and 410. Invariably there will always be one weight class that you did not count on for an extra round. See Group B at 152, bout No. 411.

On five mats, the first round this afternoon, from bout 316 to bout 362, will last about 55 minutes. The second round has only 30 bouts, or about three-quarters of an hour on four mats. The third round will have only 16. Skip 92.5 once, to help the timing, but not twice.

You can't afford to keep five mats open all the way, or you'll run into rest-time problems fairly soon. Close a mat at the start of the second round, so the second round will be on four mats.

Close another mat at the start of the third round; this is also a good time to stop sending bouts "on deck", slowing things down a little bit more. Go to one mat after the 220 pound weight class, bout 406. You have three bouts left, and they must go one at a time to avoid empty mats.

Saturday night

With adequate rest between sessions, you can use the normal order of weights, from 92.5 to 220. First run the bouts for fifth and third, grouped by weights on two, three or four mats. Then the finals, one at a time.

USA WRESTLING											
TOURNAMENT FLOW CHART				YEAR	2008		EVENT	FILA CADET			
SATURDAY AFTERNOON											
Weights	Start	Bout Nos.	Rem.	Bout Nos.	Time	Rem.	Bout Nos.	Time	Rem.	Bout Nos.	Time
92.5	2	SKIP	2	387							
B	3	SKIP	3	388							
101	6	357-359	4	389-390	2:40	2	407	3:19			
B	6	360-362	4	391-392	2:45	3	408	3:24			
110	7	316-318	5	363-364	2:01	3	393	2:50	3	409	3:21
B	6	319-321	4	365-366	2:03	2	394	2:52			
119	6	322-324	5	367-368	2:07	4	395-396	2:55			
B	6	325-327	4	369-370	2:05	2	397	2:56			
127.5	7	328-330	5	371-372	2:10	3	398	2:54	3	410	3:27
B	6	331-333	3	373	2:13	3	399	3:00			
138.5	6	334-336	4	374-375	2:17	4	400-401	3:02			
B	5	337-338	3	376	2:19	3	402	3:03			
152	6	339-341	4	377-378	2:23	3	403	3:05			
B	6	342-344	4	379-380	2:25	3	404	3:09	3	411	3:33
167.5	6	345-347	3	381	2:26	3	405	3:10			
B	5	348-349	3	382	2:27						
187	4	350-351	2	383	2:30						
B	3	352	3	384	2:32						
220	5	353-354	3	385	2:38	3	406	3:15			
B	4	355-356	2	386	2:35						

PRESENTATION OF AWARDS

As each weight moves toward a conclusion, the pairing team makes up a list of place winners for the chief pairing master to provide to the announcer for presentation of awards. The chief pairing master also should instruct the teams to scan the results for the “most falls, least time” award, if one is given.

If an “outstanding wrestler” award is scheduled, the chief pairing master must be sure that a selection committee has been appointed by the chief mat official before the final session begins. If there are team trophies, a team scoring chart must be prepared.

Awards should be presented with dignity and some ceremony. The wrestlers worked hard for these awards and should be suitably recognized. Even in events where a single round-robin is used, and contestants are allowed to leave when their competition is complete, each set of awards should receive special recognition.

Award ceremonies offer an opportunity to recognize visiting dignitaries and hard-working volunteers by introducing them to present awards to the wrestlers. It is important that the list of people who will present awards be prepared by the event coordinator well before the final session. Give the announcer a chance to check their credentials and pronunciation of their names. It’s not much of an honor to present awards if your name is mispronounced and your wrestling background is described incorrectly.

There are several methods of presenting awards. The format is determined by the event coordinator and the event director.

Traditional Methods

One of wrestling’s traditions is to conduct two finals, present awards to the first weight class, wrestle a third final, present the second set of awards, and continue this pattern. The one-bout delay allows all the medalists to gather at the awards stand. After the last bout, awards for the last two weights, team trophies and special individual awards are presented.

Another method, which provides fewer interruptions of the action, is to wrestle four finals, present awards for three weights, conduct three more finals, present three more sets of awards, and so on.

The fastest way is to present awards without stopping action on the mats. This is appropriate for youth events conducted in single round-robin style. Once the medalists are determined and have gathered at the awards stand, the announcer merely calls attention to the presentations and reads the names of the recipients.

On-the-Mat Presentations

Another format gaining popularity is presentation on the mat, immediately after conclusion of the medal bouts and finals.

One presenter is sent with two awards to the mat where third and fourth places are being contested. Another presenter handles fifth and sixth on the designated mat. If there are more places, another presenter is necessary for each pair of awards.

As soon as the medal bout ends, and the winner’s hand is raised, the presenter goes onto the mat, shakes hands with the loser and presents his/her award. He/she then congratulates the winner and presents his/her award. Except for the championship finalists, the wrestlers are now free to leave the arena. This format requires close teamwork among the officials on the mat, the

pairing officials, the announcer and the presenters of the awards, and should be directed by the event coordinator.

Awards for the finals are presented in more deliberate fashion. While the silver medal (second place award) is being presented, the champion has an opportunity to return to his/her corner, towel off and put on his/her warmup. The gold medal or championship award is presented and photographs are taken. The champion remains in uniform for the all-champions photograph taken at the end of the program.

Once the awards have been presented to the heavyweight runner-up and champion, only the team trophies and special individual awards remain to be presented.

Outstanding Wrestler

In regional and national tournaments, it is traditional to elect and recognize one champion as the outstanding wrestler of the event and present a special award. In USA Wrestling tournaments, the OW usually is chosen by a committee of mat officials.

DEALING WITH ERRORS

Perhaps the event has gone so smoothly that no errors have occurred. But as long as human beings conduct tournaments, mistakes happen. Judges record the wrong score or the wrong winner. Pairing officials record the wrong result, or the wrong classification points, or reverse them, or mis-pair. Wall charts aren't always correct. Wrestlers and coaches have questions.

Often, just plain common sense provides the best answer. Keep calm, study the situation, get the results down correctly, and get a fresh start. If it's tricky, get off by yourself, call in help and make a logical decision. Do your best to be fair to the wrestlers, all of them.

Problem

Allen pins Brown to begin the Group A finals. Then, Allen fails to make weight, while Brown and Clark do. Allen is totally eliminated. Clark beats Brown, 3-1, wins the pool and wrestles for the gold. Brown is second in the pool and wrestles for the bronze.

If Davis, who finished fourth in the pool, has weighed in for the finals (intending to wrestle for seventh place), he/she advances to third in the pool and now has the opportunity to wrestle for fifth place. No other wrestler is advanced into the seventh place bout.

Problem

In the bronze medal bout of the tournament finals, Harris from Group B is disqualified with three cautions. This does not keep him from placing fourth.

Harris would have been totally eliminated only if he/she had failed to weigh in, had failed to show up for his/her bout, or had been disqualified for flagrant misconduct. If Harris had been injured during the bout, he/she still would place fourth. Had he/she failed to show up, claiming injury, he/she would have been totally eliminated unless he/she had written verification from the chief medical officer that Harris was unable to compete.

Problem

A wrestler is paired by mistake against an opponent who has been eliminated. Stop the group and re-pair if you can. If it's too late, because bouts in the next round have begun, give the "extra" wrestler a bye (not a forfeit; a forfeit is a victory and 5 points). Move him/her to the top for the next round. This prevents giving him/her another bye later.

Problem

A wrestler is omitted by mistake from the pairing. It's too late to re-pair. Did someone else get a bye in this round? If so, attempt to pair these two. Call both wrestlers and explain. If there's no bye, give the wrestler in question a bye out of turn, then move him/her to the top.

In either of these cases, if the bouts of the next round have not yet started, you have time to re-pair. Hold up the group until you have a chance to make corrections. Announce to the wrestlers that the group is being re-paired and will be delayed. Alert the following weight class to be ready to wrestle.

Any time a wrestler receives a bye — for any reason, even because of a mistake — he/she moves to the top for the next round.

Problem

A wrestler reports to the mat too soon and wrestles the wrong opponent. Wait 15 minutes and reassign the proper wrestlers to the mats after the mandatory rest period. If the wrestlers are in different weights or pools, discard the result of the “wrong” bout. If they are in the same group and might meet later, hold onto the score sheet. If they are properly paired later, the result of the “wrong” bout will count in that round. Explain this to the wrestlers and their coaches.

Problem

Upon recording an injury default which does not eliminate the injured athlete, call for the wrestler, his/her coach or the chief medical officer to determine whether the wrestler is able to continue. If he/she definitely must withdraw, have his/her coach or the medical officer initial the pairing chart and eliminate him with the classification points he/she has earned. He/she is eligible to place. If the injured wrestler plans to continue, the decision is covered by the Medical Alert system.

Problem

The pairing is correct, but the wrong wrestler's name is written on the bout sheet. The wrestlers are called to the mat and the bout begins. The coach of one of the wrestlers comes to the table and complains that the wrong opponents are wrestling. Stop the bout, wait 15 minutes and reassign the proper wrestlers to the mat after the mandatory 15 minute rest period.

A Last Word

If a “wrong” bout is wrestling, stop the match at any time before conclusion. Wait 15 minutes and reassign the proper wrestlers to the mats after the mandatory rest period. Do not let the “wrong” bout wrestle to conclusion if it can be stopped. Never be too proud, or too nervous, to admit that a mistake has been made. Mistakes do happen, despite our best efforts. Almost always, the wrestlers and coaches will accept a mistake when they understand what's going on, and when they realize that we're trying our best to solve the problem in a fair, open manner.

USA Procedures

GUIDELINES FOR USAW NATIONAL & REGIONAL EVENTS

The purpose of these guidelines is to standardize operations at USA Wrestling regional and national championships, with goals of increasing participation, enhancing value, building continuity in the event series and promoting our sport.

All USAW sanctioned regional and national competitions shall in general be governed by the FILA rules, with USA Wrestling modifications where applicable. Any other modifications may be made only by the designated USA Wrestling representative on site (event coordinator).

The event shall be organized by the host Local Organizing Committee (LOC) with guidance from USA Wrestling. The contract to organize and stage the event is made between the LOC and USA Wrestling to help ensure that these events are of the quality that all of USA Wrestling desires. Contract compliance is the responsibility of the event coordinator. Questions or concerns regarding contract interpretation should be directed to this individual.

The correct, official name of the event shall always be used. The event is sanctioned by USA Wrestling and is a part of its national event series. USA Wrestling shall be prominently displayed and receive appropriate recognition on all promotional materials.

All athletes participating in any competition that is part of the event shall be afforded an opportunity to register before the start of the first session for which there is an admission charge. USA Wrestling athlete memberships shall be available for purchase at registration.

One or more weigh-ins may be required.

A meeting shall be scheduled before the start of competition where the chief mat official can address the coaches and officials as a group and, at the same time, coaches may ask questions or address concerns to the chief mat official or event director.

Complete uniforms, in conformance with the rules, shall be encouraged and in most cases is mandatory. This means red and blue singlets, or a red/blue reversible singlet with underbriefs, plus a handkerchief.

Officials will use scoring paddles and blocks on each mat, when possible.

An announcer or announcers shall be assigned. Contestants shall be directed by the announcer to report directly to a specific mat for competition.

Medal matches may run in flights by weight class, following the conclusion of all group finals. National Championship matches for the Cadet Division and older age groups shall be conducted in order on one mat. If the event includes competition for more than one age group or style, an effort shall be made to set off and create one or more "final sessions" for the event.

An equal number of identical awards should be offered in both freestyle and Greco-Roman for each age group. A minimum of three places and a maximum of eight places shall be offered per weight class. Champions also should be presented the completed wall chart and one of the finals bout sheets.

There should be a bona fide awards presentation made following the conclusion of the championship bout in each weight class or age group, and no awards shall be distributed prior to this ceremony at any Junior or University Division regional, when feasible. Kids/Cadet regional directors are encouraged to follow the same procedure.

REGISTRATION AND WEIGH-IN

Registration and weigh-in must be conducted under the rules and procedures of USA Wrestling for the event. Compliance is the responsibility of the event coordinator and the entire operations team.

Individual and team registrations must be completed within the specified time period. Completion of registration means the following:

- Submission of all entry forms, payment of all fees and presentation of required licenses, membership cards and identification to the registrar within the time period specified.
- Submission of a completed weigh-in card to the weighmaster within the time period specified for the initial weigh-in.

The registration area should be open for at least 60 minutes before the initial weigh-in. All forms shall be available to potential entrants at registration. Signs should be posted to direct the flow of traffic smoothly through the registration and weigh-in process.

Only official personnel (wrestlers, supervisors and staff) shall be allowed in the weigh-in area. Provisions shall be made to weigh female competitors separately and apart from male competitors.

A Contestants draw number must be written on their weigh-in card. This process shall be overseen by the drawmaster or his/her designee. This process will take place at time of registration or be conducted prior to weigh-ins.

Contestants shall then line up in single file behind a designated floor marking, with only the wrestler to be weighed crossing this line when called. Approaching the scale, the contestant shall be wearing a singlet, and he/she shall present his/her weigh-in card to the official at the scale. A medical check maybe performed at this time or prior to or just before the athlete draws a number. The official shall read from the card, announcing the contestant's name, affiliation and the weight he/she is attempting to make. If any of these are incorrect or missing, or the weigh-in card is not legible, the contestant will be told to correct the card and start again at the end of the line.

If the weigh-in card is correct, the contestant shall step upon the scale. He/she shall stand with both feet flat in the middle of the scale facing away from the dial, bar or screen. If he/she makes the designated weight, it will be written on his/her shoulder and verified on his/her card.

If he/she fails to make the designated weight, his/her card shall not be returned to him/her and he/she will be taken immediately to the official challenge scale for a FINAL attempt to make the desired weight, or failing that opt for another weight class (if regulations permit). An athlete shall only have two opportunities to make the weight class. This is not applicable for the Senior Division or events qualifying for FILA level competition.

Weigh-in cards shall be sorted by weight class and given to the chief pairing master during the course of the weigh-in. Cards are not available for review by coaches or contestants unless such review is approved by the chief pairing master.

For all weigh-ins, they begin at the designated time and end once the final contestant has attempted to weigh-in, or as stipulated for the event. All athletes must be present at time of weigh-ins. For Senior level events and FILA level qualifying events, weigh-ins shall have a beginning and ending time. The weighmaster should periodically call out the time remaining and should call the remaining entrants to the scales near the close of the weigh-in period.

Late registrations or weigh-ins may only be approved by the event coordinator, and only when extenuating circumstances prevent the athlete or team from entering within the specified time period. Extenuating circumstances may include, but are not limited to, automobile accidents or mechanical breakdowns, canceled or delayed airline flights, and suddenly hazardous weather conditions. This does not apply to Senior National Events, Olympic or World Team Trials, or any tournament used to qualify for such tournaments.

When his/her late registration and weigh-in form is accepted, the entrant shall have 30 minutes to complete registration and weigh in.

THE EVENT COORDINATOR

It is the responsibility of the event coordinator to see that the event is conducted under terms of the contract, that it follows all applicable FILA and USA Wrestling regulations, and that it maintains standards desired of USA Wrestling events. The coordinator should make every effort to enhance the prestige, effectiveness and image of the event, while relying on the volunteer experts to make it work.

Whether you are the event coordinator or one of the volunteers working with him, remember that you are part of the same team and you have the same goal, a high quality event. Diplomacy and tact may be your most efficient tools. A low key, "smooth and soothe" approach usually precludes the need for hard-line decisions.

Before the Event

The event coordinator should communicate at least monthly with the event director. During the final month, such communication should be weekly, or even daily. If feasible, the coordinator should meet with the event director at least one month before the event and should inspect all facilities.

He/she should schedule and conduct a formal meeting with the event director the day before the event, to review all aspects of the event in detail and set action plans in motion to cure any deficiencies.

The event coordinator should present all known invoice data, including estimates of anticipated expenses, to the event director 10 days before the event.

The coordinator should complete his/her travel and lodging arrangements well ahead of the event and should take to the event all necessary items not already shipped there by USA Wrestling.

During the Event

The event coordinator should perform the following duties:

- Oversee proper setup of facilities and equipment.
- Oversee and ensure proper registration and make final rulings on any requests for registration outside regulations.
- Oversee and ensure proper weigh-ins, and make final rulings on any requests for weigh-ins outside the regulations.
- Recommend procedures to enhance the image of the event.
- Verify that appropriate arrangements have been made for room, board, hospitality and travel, and verify that this information has been communicated to appropriate parties.
- Verify that appropriate arrangements have been made for all reimbursements, per diem allowances, etc., and ensure that such disbursements are made before the end of the event.
- Coordinate the start and end of each session, in consultation with the chief pairing master and chief mat official.

- Ensure that public address announcements (camps, clinics, qualifying, upcoming events, sponsorship commitments, etc.) are provided to the chief pairing master for the announcer.
- Prepare in advance for the finals and awards presentations, arranging for presenters and coordinating the program with the chief pairing master, announcer and chief mat official.
- Present USA Wrestling gift to the event director.
- Assist in developing meeting agendas, and the preparation and distribution of meeting supplies and minutes.
- Ensure compliance with the contract.
- Present the invoice to the LOC and collect payment of same. If full payment is not possible, collect as much as is feasible.
- Collect results and forward in a timely manner to the media and immediately to USA Wrestling headquarters.

After the Event

The event coordinator should promptly deliver to the Department of National Events copies of the event souvenir program, all film collected from event photographers and copies of all local press coverage.

The event coordinator should promptly deliver all results to the Events Department for entry into appropriate data bases and files.

Within 10 days following the event, the event coordinator should deliver to the Manager of Events a post-event report which should include the following:

- Completed budget vs. actual financial statement.
- Invoice and payment on invoice.
- Number of entries per age group per style.
- Number of paid spectators and their demographics.
- Number of comp spectators and their constituencies.
- A description of media participation and coverage.
- An “as-done” schedule.
- A suggested schedule for next time.
- Number of officials, type and category.
- Medical personnel and their competency.
- Analysis of the effectiveness of the LOC and event director.
- Suggestions for improvements of the event and the LOC.
- Other pertinent comments.

Index

2012 Guide to Wrestling

USA Modifications	Page
Blood Rule	63
Pairing Procedures	63
Weigh-ins and Drawing of Lots	64
Tournament Committee	64
Senior Division	65
University Division	66
FILA Junior World Division	67
Junior, FILA Cadet, Cadet and Kids Division Regulations of Note	67
Junior Division	69
Cadet Division	73
FILA Cadet Division	74
Kids Division	75
Glossary	
International Terms and Definitions	81
International Country Codes	89
A Guide to Pairing	
Modifications	90
Double Elimination Bracketing	91
Bye and Seed Placement	96,98
The Flow Chart	99
Vertical Pairing Format	100
Weigh-ins	101,64
Drawing of Lots	101,64
Pairing Procedures	104,63
Recording	106
Standard Notations	108
Re-Pairing a Round	109
Classification	110
Tournament Operations	
The Big Picture	116
Tournament Planning Formulas	116
Planning the Schedule	118
Table of Mats and Hours	119
Team Concept	120
Chief Pairing Master	121,123
The Flow Chart	124
Presentation of Awards	129
Dealing With Errors	130
USA Procedures	
Guidelines for National & Regional Events	132
Registration and Weigh-In	133,64
The Event Coordinator	134
Weight Classes and Age Group Charts	
Weight Classes and Age Groups	137,138



2012 - MEN'S AGE DIVISIONS and WEIGHT CLASSES

AGE DIVISIONS	BIRTH DATES	FREESTYLE/GRECO MATCH TIME LIMITS	FOLKSTYLE MATCH TIME LIMITS	WEIGHT CLASSES
BANTAM	Born 2004-2005	Best out of 3 two-minute periods with 30 second rest between periods	Championship and Consolation: 3 one-minute periods	40, 45, 50, 55, 60, 65, 70, 75, 75+ (15 lbs. maximum difference)
INTERMEDIATE	Born 2002-2003	Best out of 3 two-minute periods with 30 second rest between periods	Championship and Consolation: 3 one-minute periods	50, 55, 60, 65, 70, 75, 80, 87, 95, 103, 112, 120, 120+ (20 lbs. max difference)
NOVICE	Born 2000-2001	Best out of 3 two-minute periods with 30 second rest between periods	Championship: 1 one-minute and 2 1:30 periods; Consolation: 3 one-minute periods	60, 65, 70, 75, 80, 85, 90, 95, 100, 105, 112, 120, 130, 140, 140+ (25 lbs. maximum difference)
SCHOOLBOY	Born 1998-1999	Best out of 3 two-minute periods with 30 second rest between periods	Championship: 1 one-minute and 2 1:30 periods; Consolation: 3 one-minute periods	70, 77, 84, 91, 98, 105, 112, 120, 128, 136, 144, 152, 160, 175, 190, 210, 265
CADET (Men)	Born 1996-1997	Best out of 3 two-minute periods with 30 second rest between periods	Championship: 3 two-minute periods; Consolation: 1 one-minute and 2 two-minute periods	88, 94, 100, 106, 113, 120, 126, 132, 138, 145, 152, 160, 170, 182, 195, 220, 285
FILA CADET (Men)	Born 1995-1997	Best out of 3 two-minute periods with 30 second rest between periods	N/A	39-42 KG/86-92.5 LBS. , 46/101.25, 50/110.25, 54/119, 58/127.75, 63/138.75, 69/152, 76/167.5, 85/187.25, 85-100/187.25-220.5, 125/275.5
JUNIOR (Men)	Born 9/1/1992 & after, plus enrolled in grades 9-12	Best out of 3 two-minute periods with 30 second rest between periods	Championship: 3 two-minute periods; Consolation: 1 one-minute and 2 two-minute periods	100, 106, 113, 120, 126, 132, 138, 145, 152, 160, 170, 182, 195, 220, 285
FILA JUNIOR WORLD (Men)	Born 1992-1994 with medical certificate	Best out of 3 two-minute periods with 30 second rest between periods	N/A	46-50 KG/101.25-110.25 LBS. , 55/121.25, 60/132.25, 63/138.75*, 66/145.5, 70/154.25*, 74/163, 79/174*, 84/185, 96/211.5, 120/264.5
UNIVERSITY (Men)	Born 1988-1994 & athlete must have graduated from high school	Best out of 3 two-minute periods with 30 second rest between periods	N/A	55 KG/121.25 LBS. , 60/132.25, 63/138.75*, 66/145.5, 70/154.25*, 74/163, 79/174*, 84/185, 96/211.5, 120/264.5
SENIOR (Men)	Born 1992 or before 1993-1994 with medical certificate	Best out of 3 two-minute periods with 30 second rest between periods	N/A	55 KG/121.25 LBS. , 60/132.25, 66/145.5, 74/163, 84/185, 96/211.5, 120/264.5
USA WRESTLING VETERANS (Men—All Styles)	Div. A: Born during the years of 1980 and 1987 Div. B: Born during the years of 1972 and 1979 Div. C: Born during the years of 1964 and 1971 Div. D: Born during the years of 1957 and 1963 Div. E: Born 1956 and before.	Best out of 3 two-minute periods with 30 second rest between periods	Championship: 1 one-minute and 2 1:30 periods; Consolation: 3 one-minute periods	50-58 KG/110.25-127.75 LBS. , 63/138.75, 69/152, 76/167.5, 85/187.25, 97/213.75, 97-130/213.75 - 286.5

* Not a FILA weight

Chart is effective from September 1, 2011 to August 31, 2012



2012 - WOMEN'S AGE DIVISIONS and WEIGHT CLASSES

AGE DIVISIONS	BIRTH DATES	FREESTYLE/GRECO MATCH TIME LIMITS	FOLKSTYLE MATCH TIME LIMITS	WEIGHT CLASSES
INTERMEDIATE	Born 2003-2005	Best out of 3 two-minute periods with 30 second rest between periods	Championship and Consolation: 3 one-minute periods	45, 50, 55, 60, 65, 70, 75, 80, 85, 85+
NOVICE	Born 2000-2002	Best out of 3 two-minute periods with 30 second rest between periods	Championship: 1 one-minute and 2 1:30 periods; Consolation: 3 one-minute periods	60, 65, 70, 75, 80, 85, 90, 95, 102, 110, 118, 118+
SCHOOLGIRL	Born 1998-1999	Best out of 3 two-minute periods with 30 second rest between periods	Championship: 1 one-minute and 2 1:30 periods; Consolation: 3 one-minute periods	81, 89, 97, 105, 113, 120, 128, 137, 145, 155, 175, 195
CADET (Women)	Born 1996-1997	Best out of 3 two-minute periods with 30 second rest between periods	Championship: 3 two-minute periods; Consolation: 1 one-minute and 2 two-minute periods	84, 88, 95, 101, 108, 115, 124, 132, 143, 154, 172, 198
FILA CADET (Women)	Born 1995-1997	Best out of 3 two-minute periods with 30 second rest between periods	N/A	36-38 KG /79.25-83.75 LBS, 40/88 , 43/94.75 , 46/101.25 , 49/108 , 52/114.5 , 56/123.5 , 60/132.25 , 65/143.25 , 70/154.25 , 78/172* , 84/185* , 100/220.5*
JUNIOR (Women)	Born 9/1/1992 & after, plus enrolled in grades 9-12	Best out of 3 two-minute periods with 30 second rest between periods	Championship: 3 two-minute periods; Consolation: 1 one-minute and 2 two-minute periods	97, 105, 112, 117, 121, 125, 130, 139, 148, 159, 172, 198
FILA JUNIOR WORLD (Women)	Born 1992-1994 with medical certificate	Best out of 3 two-minute periods with 30 second rest between periods	N/A	40-44 KG /88-97 LBS, 48/105.75 , 51/112.25 , 55/121.25 , 59/130 , 63/138.75 , 67/147.5 , 72/158.75 , 79.5/175.25*
UNIVERSITY (Women)	Born 1988-1994 & athlete must have graduated from high school	Best out of 3 two-minute periods with 30 second rest between periods	N/A	48 KG /105.75 LBS, 51/112.25 , 55/121.25 , 59/130 , 63/138.75 , 67/147.5 , 72/158.75 , 77/169.75*
SENIOR (Women)	Born 1992 or before 1993-1995 with medical certificate	Best out of 3 two-minute periods with 30 second rest between periods	N/A	48 KG /105.75 LBS, 51/112.25 , 55/121.25 , 59/130 , 63/138.75 , 67/147.5 , 72/158.75

* Not a FILA weight

Chart is effective from September 1, 2011 to August 31, 2012

Junior Greco Nationals . Junior 98A

NO	NAME	1		2		3		4		5		6		7		RR1	RR2	RR3	FINISH	
101	ADAM ANDERSON	3	5	7	11											19	--	5	2	
	MINNESOTA	D 12-7 5-1	3	4-5 2-3	X	D 6-2 3-1	3	TF 8-0 8-0	4							D 8-5 8-3	3	--		0
103	BEAU BROCKMAN	1	7																—	
	IDAHO	7-12 1-6	X	3-5 1-2	X															
105	CHRIS COPPERFIELD	7	1	11	13											BYE			3	
	WISCONSIN	D 6-2 3-2	3	D 5-4 3-2	3	D 8-7 1-2 3-1	3	D 3-2 1-2 4-2	3							--	0	19		1
107	DANE DREKLER	5	3	1															—	
	GEORGIA	2-8 2-3	X	D 5-3 2-1	3	2-8 1-3	X													
109	ETHAN ELLENSBURGER	11	13																—	
	CALIFORNIA	LF	X	LF	X															
111	FRANK FELLSMAN	9	17	5	1														—	
	OKLAHOMA	F 2-43	5	WBF	5	7-8 2-1 1-3	X	0-8 0-8	X							13	2-4 1-2	X		
113	GREG GRUNDE	15	9	19	5														4	
	INDIANA	F 6-0 1-2 1:19	5	F 1:37	5	LF	X	2-3 2-1 2-4	X							D 4-2 2-1	3			
115	HARRY HAMILTON	13	19																—	
	NEVADA	LF	X	14-15 3-7	X															
117	IAN ILLMAN	EJECTED																		E
	MINNESOTA	19	11																	
119	JUSTIN JORGENSEN	17	15	13	--														1	
	WISCONSIN	F 1:27	5	D 15-14 7-3	3	F 1:57	5	--	0									1		5

Brackets Created By Trackwrestling.com

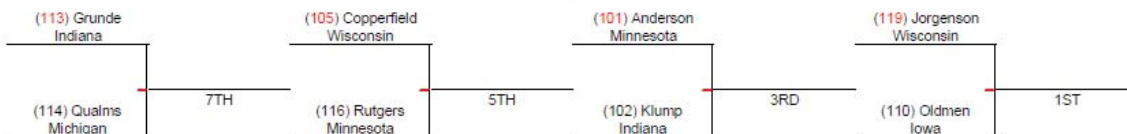

Junior Greco Nationals . Junior 98B

NO	NAME	1	2	3	4	5	6	7	RR1	RR2	RR3	FINISH
102	KEN KLUMP	4	18	8	16	14			10			2
	INDIANA	F 0:52 5	F 1:58 5	WBI 5	2-3 1-3 X	F 2:5 7-6 0:24 5			1-7 2-8 1			
104	LARRY LUND	2	6									—
	CALIFORNIA	LF X	10-12 1-3 X									
106	MORGAN MANFELDER	8	4	10								—
	WISCONSIN	0-6 0-6 X	D 12-10 3-1 3	LF X								
108	NICK NEIS	6	10	2								—
	FLORIDA	TF 6-0 6-0 4	LF X	INJ X								
110	ORION OLDMEN	12	8	6	16				2			1
	IOWA	F 1:58 5	F 1-2 3-1 0:08 5	F 1:28 5	-- 0	D 8-4 7-2 3			TF 7-1 8-2 4			
112	PETE PETERSON	10	14									—
	MINNESOTA	LF X	FORF X									
114	QUINN QUALMS	16	12	--	18	2						4
	MICHIGAN	1-3 2-3 X	WBF 5	-- 0	D 6-1 4-2 3	LF X						
116	RON RUTGERS	14	--	18	2	10			X			3
	MINNESOTA	D 3-1 3-2 3	-- 0	DQ X	D 3-2 3-1 3	4-8 2-7 X						
118	SAM SAUNDERS	--	2	16	14							—
	MICHIGAN	-- 0	LF X	WBD 5	1-6 2-4 X							

Brackets Created By Trackwrestling.com

NOTES

NOTES

HOLDING A TOURNAMENT?

We have the supplies you need!

- Double Elimination Wall Brackets #10501 \$1.00
32-man on one side, 16-man on the reverse side
Each accompanied by two matching table sheets
- Scholastic Wall Bracket, 8 man #10507 \$0.75
Each accompanied by two matching table sheets
- Scholastic Bout Sheets, pad of 100 \$3.00
Blue #10532 Green #10533
White #10534 Yellow #10535
- Vertical Wall Charts, 12-man #10503 \$0.75
Each accompanied by two 12-man pairing sheets
- Freestyle Bout Sheets, pad of 100 \$5.00
Blue #10518 Green #10516
White #10520 Yellow #10521
Pink #10519 Tan #10514
Grey #10515 Orange #10517
- Weigh-in Cards, pad of 50 \$2.50
Blue #10523 Green #10529
White #10525 Yellow #10526
Pink #10524 Tan #10527
Grey #10528 Orange #10530
- Floor Passes, pad of 100 \$5.00
Blue #10581 Green #10583
White #10580 Yellow #10582
- All-Session Passes, pad of 100 \$5.00
Pink #10584 Tan #10585
- Official USAW Logo Table Skirting \$1.00/lin. ft.
200 ft. rolls \$150.00

Shipping and handling charges not included in these prices



USA WRESTLING



www.themat.com

6155 Lehman Drive, Colorado Springs, CO 80918

Call: 1-719-598-8181

U S A W R E S T L I N G

6155 Lehman Drive

Colorado Springs, CO 80918

NON-PROFIT ORG.

U.S. POSTAGE

PAID

Colo. Springs, CO

Permit No. 39

U S A W R E S T L I N G R U L E B O O K A N D G U I D E 2 0 2 1 0 2